

Module 3 : Sequence Components and Fault Analysis

Lecture 10 : Sequence Components

Objectives

In this lecture we will

- Introduce sequence components.
- Extract positive, negative and zero sequence components from 3ϕ unbalanced phasors.
- Synthesize a 3ϕ unbalanced phasor using sequence components.
- Analyze 3ϕ , S-L-G, L-L and L-L-G faults using sequence components.

10.1 Introduction

Electrical systems occasionally experience short circuits. These short circuits are hazardous to the safety of both equipment and people. Though the protective devices will isolate the faults safely, the parts of the system should withstand the resulting mechanical and thermal stresses. Fault impedance and fault current estimates also form input for the setting and coordination of protective devices like overcurrent relay, distance relay etc. Hence it is very important to estimate the magnitude of the fault currents. The equipment rating are decided based on this value. Fault currents can be estimated either by hand calculation or by fault analysis program.

Sources of Fault Current

The fault current in a system can be contributed by any of the following.

- Synchronous Motors and Condensers
- Induction Machines
- Synchronous Generators
- Electrical Utility System
- Distributed Generation

10.2 Sequence Components

Faults in a 3 phase system can be single line to ground, double line to ground, line to line or three phase. Power system operation during any of these faults can be analyzed using sequence components. The method of sequence component was discovered by Charles L. Fortescue in 1918. He came up with the following intuition that any 3ϕ unbalanced system has 6 degrees of freedom; whereas, a 3ϕ balanced system has only 2 degrees of freedom. Hence an unbalanced 3ϕ system having 6 degrees of freedom can be synthesized by 3 sets of balanced system each having 2 degrees of freedom.

Note: This idea can be easily extended to N-phase system where .

$$N \geq 3$$

For a three phase system with phase sequence a-b-c, the three sets of balanced phasors are called positive, negative and zero sequences.

10.2 Sequence Components (contd..)

10.2.1 Positive Sequence Component

It represents a set of balanced phasors \vec{V}_{a1} , \vec{V}_{b1} and \vec{V}_{c1} . If we choose 'a' phase as reference phasor.

$$\vec{V}_{b1} = \alpha^2 \vec{V}_{a1} \quad (1)$$

$$\vec{V}_{c1} = \alpha \vec{V}_{a1} \quad (2)$$

Where $\alpha = e^{j2\pi/3}$

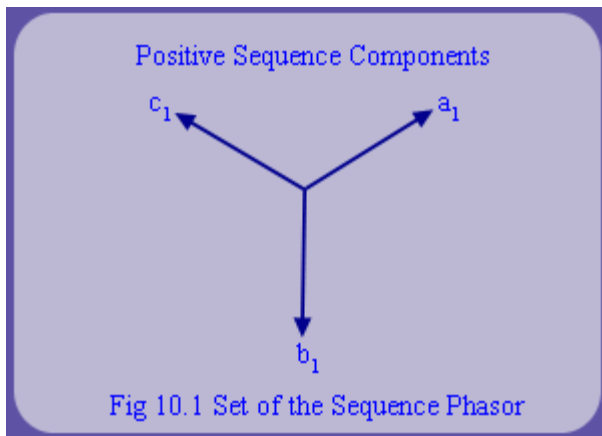

'a' is cubic root of unity. Multiplying a phasor by 'a' causes a rotation of 120° in the anticlockwise direction (lead of 120°). Similar usage of a^2 results in 240° in the anticlockwise direction or equivalently a lag of 120° . The positive sequence of phasors is the same balanced set of phasors that we expect in steady operation of an ideal power system. Thus, a, b and c phasors are nothing but V_{a1} , V_{b1} and V_{c1} respectively. The sequence phasors are shown in fig 10.1. If the stator of an induction motor is subjected to positive sequence voltage, it should cause rotation in anticlockwise direction. Note that placement of V_{a1} can be done arbitrarily in the x-y plane. But once, V_{a1} is fixed both V_{b1} and V_{c1} are fixed.

Thus, a positive sequence set of phasors have 2 degrees of freedom i.e. we can decide placement of $|V_{a1}|$ (magnitude) and $\angle V_{a1}$ arbitrarily.

10.2 Sequence Components (contd..)

10.2.2 Negative Sequence Component

Negative sequence phasors are used to represent a balanced set of phasors (each of equal magnitude and phase difference of 120°) but in which the order of V_b and V_c has been reversed with respect to the positive sequence phasor. Thus,

$$\vec{V}_{b2} = \alpha \vec{V}_{a2} \quad (3)$$

$$\vec{V}_{c2} = \alpha^2 \vec{V}_{a2} \quad (4)$$

This is illustrated in fig 10.2. Note that placement of V_{a2} in x - y plane can be done arbitrarily. However, once V_{a2} is fixed both V_{b2} and V_{c2} are automatically fixed. Thus, negative sequence component have exactly two degrees of freedom which is to fix magnitude and angle of V_{a2} .

If stator of a 3ϕ induction motor is subject to negative sequence voltage the rotor will rotate in a clockwise direction. i.e. in exactly opposite direction to that obtained with the positive sequence voltage.

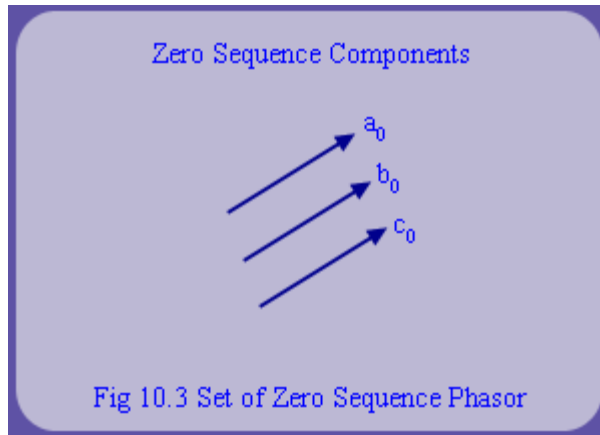
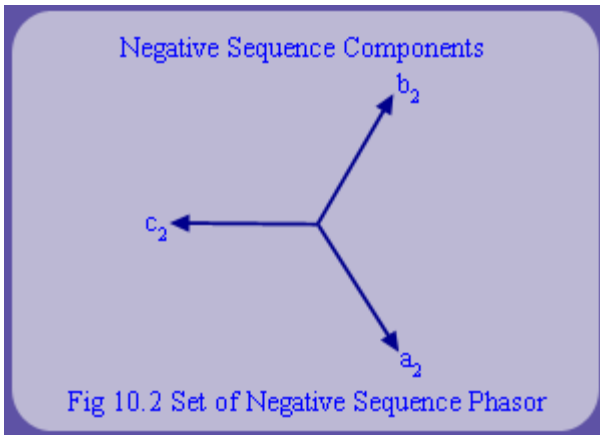

10.2.3 Zero Sequence Component

The zero sequence phasors V_{a0} , V_{b0} and V_{c0} are a set of balanced phasors defined as follows.

$$\vec{V}_{a0} = \vec{V}_{b0} = \vec{V}_{c0} \quad (5)$$

10.2 Sequence Components (contd..)

10.2.2 Zero Sequence Component (contd..)

Again there are two degrees of freedom in placing the zero sequence phasors. Application of zero sequence does not create any rotation to the rotor of an induction machine. This is because the net mmf induced in the air gap is zero.

An unbalanced set of phasors can be synthesized by linear combination (superposition of positive, negative and zero sequence phasors).

For example,

10.3 Mathematical description of sequence components

So far we have seen that,

$$\vec{V}_a = \vec{V}_{a1} + \vec{V}_{a2} + \vec{V}_{a0}$$

$$\vec{V}_b = \vec{V}_{b1} + \vec{V}_{b2} + \vec{V}_{b0}$$

$$\vec{V}_c = \vec{V}_{c1} + \vec{V}_{c2} + \vec{V}_{c0}$$

Using equation (1) to (5), we get

$$\begin{bmatrix} V_a \\ V_b \\ V_c \end{bmatrix} = \begin{bmatrix} 1 & 1 & 1 \\ 1 & a^2 & a \\ 1 & a & a^2 \end{bmatrix} \begin{bmatrix} V_{a0} \\ V_{a1} \\ V_{a2} \end{bmatrix} \quad (6)$$

or stated more compactly,

$$[V^{abc}] = [T][V_a^{012}] \text{ where } T = \begin{bmatrix} 1 & 1 & 1 \\ 1 & a^2 & a \\ 1 & a & a^2 \end{bmatrix} \text{ and } a = e^{j2\pi/3}$$

Matrix [T] defines a linear transformation of phasors from sequence domain to phase domain. Matrix [T] enjoys some interesting properties. For example, every pair of rows or columns of matrix [T] are orthogonal. For example,

$$\text{If } c_1 = (1, 1, 1)^t \text{ and } c_2 = (1, a^2, a)^t$$

Then, $(c_1)^H c_2 = (c_2)^H c_1 = 0$ where H is Hermitian operator defined as transpose and conjugate of a vector or matrix.

Similarly,

In other words, $T^H T = T T^H = D$, where D is a diagonal matrix

$$\text{With } D = \begin{bmatrix} 3 & 0 & 0 \\ 0 & 3 & 0 \\ 0 & 0 & 3 \end{bmatrix}$$

It can be verified that

$$T^{-1} = \frac{1}{3} T^H = \frac{1}{3} \begin{bmatrix} 1 & 1 & 1 \\ 1 & a & a^2 \\ 1 & a^2 & a \end{bmatrix}$$

$$\text{and } \begin{bmatrix} V_{a0} \\ V_{a1} \\ V_{a2} \end{bmatrix} = \frac{1}{3} \begin{bmatrix} 1 & 1 & 1 \\ 1 & a & a^2 \\ 1 & a^2 & a \end{bmatrix} \begin{bmatrix} V_a \\ V_b \\ V_c \end{bmatrix} \quad (7)$$

10.3 Mathematical description of sequence components (contd..)

10.3.1 Geometrical interpretation

We illustrate the inverse transformation for phase to sequence domain by geometrical method. We are given a set of unbalanced phasors and we have to compute the sequence components from it. Algebraically, it is simply application of equation (7). Geometrically, it can be interpreted by noting that 'a' represents 120° rotation of phasor in anticlockwise direction and a² is 240° rotation of phasor in anticlockwise direction.

10.3 Mathematical description of sequence components (contd..)

10.3.2 Significance of Transformation

One should understand the significance of linearity in sequence component transformation clearly.

- Sequence transformation matrix $[T]$ provides a methodology to convert sequence domain phasors to phase domain phasors.
- Conversely, inverse transformation matrix $[T^{-1}]$ provides a mechanism to convert phasors in a-b-c domain to sequence domain. This is typically required for analysis purpose. Also, the mapping between phase domain and sequence domain is 1:1.
- There is no loss of information in either domain. In other words, both domains have identical information content.
- The transformations $[T]$ and $[T^{-1}]$ are linear i.e. if V_x^{abc} and V_y^{abc} are two sets of three phase phasors in a-b-c domain,

then superposition V_x^{abc} and V_y^{abc} in phase domain is equivalent to corresponding superposition in sequence domain. Conversely, if we superpose phasors in sequence domain, then in a-b-c domain also it amounts to equivalent superposition of phasors. Thus,

$$T^{-1}(\alpha V_x^{abc} + \beta V_y^{abc}) = \alpha T^{-1}(V_x^{abc}) + \beta T^{-1}(V_y^{abc})$$

$$= \alpha V_x^{012} + \beta V_y^{012}$$

Where $V_x^{012} = [V_x^0, V_x^1, V_x^2]$, $V_y^{012} = [V_y^0, V_y^1, V_y^2]$ and α and β are complex numbers.

$$\text{Similarly, } T(\alpha V_x^{012} + \beta V_y^{012}) = \alpha T(V_x^{012}) + \beta T(V_y^{012})$$

$$= \alpha V_x^{abc} + \beta V_y^{abc}$$

Sequence components provide a methodology to view unbalanced phasors as a set of balanced phasors. If a network is balanced, then the resulting analysis gets extremely simplified. This is because we are

able to break a three phase network into three decoupled sequence networks (under some acceptable symmetry assumptions). We now elaborate on this concept of decoupled sequence networks.

10.4 Modeling Network in Sequence Components

We now show that corresponding network modeling can also be simplified in sequence domain. If the three phase network elements enjoy a particular symmetry (circulant structure) then, application of sequence component transformation diagonalizes three phase impedance or admittance matrix. Thus, we achieve decoupling in positive, negative and zero sequence networks, provided that network is balanced. Hence, sequence component analysis is used when network is balanced but phasors or loads are unbalanced. To begin with, consider a transposed transmission line whose three phase model is given by the following equation. Z_s is the self impedance of transmission line and Z_m is the mutual impedance between two phases. These quantities can be evaluated from GMD and GMR of transmission line. ΔV_a , ΔV_b and ΔV_c is the drop in phase voltage across the line due to currents I_a , I_b and I_c respectively then,

$$\underbrace{\begin{bmatrix} \Delta V_a \\ \Delta V_b \\ \Delta V_c \end{bmatrix}}_{\Delta V^{abc}} = \underbrace{\begin{bmatrix} Z_s & Z_m & Z_m \\ Z_m & Z_s & Z_m \\ Z_m & Z_m & Z_s \end{bmatrix}}_{Z^{abc}} \underbrace{\begin{bmatrix} I_a \\ I_b \\ I_c \end{bmatrix}}_{I^{abc}} \quad (8)$$

Applying the transformation,

$$\begin{bmatrix} I_a \\ I_b \\ I_c \end{bmatrix} = [T] \begin{bmatrix} I_a^0 \\ I_a^1 \\ I_a^2 \end{bmatrix}$$

and

$$\begin{bmatrix} \Delta V_a \\ \Delta V_b \\ \Delta V_c \end{bmatrix} = [T] \begin{bmatrix} \Delta V_a^0 \\ \Delta V_a^1 \\ \Delta V_a^2 \end{bmatrix} \text{ with phase 'a' as reference phasor.}$$

we get, $[\Delta V^{012}] = [T^{-1}] [Z] [T] [I^{012}]$

Where $[T] = \begin{bmatrix} 1 & 1 & 1 \\ 1 & a^2 & a \\ 1 & a & a^2 \end{bmatrix}$ And $a = e^{j2\pi/3}$

Hence,

$$\begin{bmatrix} \Delta V_a^0 \\ \Delta V_a^1 \\ \Delta V_a^2 \end{bmatrix} = \begin{bmatrix} Z_s + 2Z_m & 0 & 0 \\ 0 & Z_s - Z_m & 0 \\ 0 & 0 & Z_s - Z_m \end{bmatrix} \begin{bmatrix} I_a^0 \\ I_a^1 \\ I_a^2 \end{bmatrix} \quad (9)$$

10.4 Modeling Network in Sequence Components (contd..)

Let $Z_0 = Z_s + 2Z_m$

$Z_1 = Z_s - Z_m$

$Z_2 = Z_s - Z_m$

Then equation (8) can be decoupled into three separate equations one for each sequence component as follows.

$$\Delta V_0 = Z_0 I_0, \quad \Delta V_1 = Z_1 I_1 \text{ and } \Delta V_2 = Z_2 I_2$$

Also, note that Z_0 , Z_1 and Z_2 are the eigen values of the phase-impedance matrix Z_{abc} . Reference phasor subscript 'a' has been dropped for convenience.

Thus, we see that positive, negative and zero sequence networks are decoupled. In general, if Z matrix has following circulant symmetry we can decouple the positive, negative and zero sequence networks by sequence transformation T. It can be shown that if,

$$, \text{ then } Z_{012} = T^{-1} [Z_{abc}] T$$

$$Z_{abc} = \begin{bmatrix} Z_s & Z_{m1} & Z_{m2} \\ Z_{m2} & Z_s & Z_{m1} \\ Z_{m1} & Z_{m2} & Z_s \end{bmatrix}$$

where $Z_0 = Z_s + Z_{m1} + Z_{m2}$

$$Z_1 = Z_s + a^2 Z_{m1} + a Z_{m2} = \begin{bmatrix} Z_0 \\ Z_1 \\ Z_2 \end{bmatrix} \quad (10)$$

$$Z_2 = Z_s + a Z_{m1} + a^2 Z_{m2}$$

Thus, all the sequence components can be determined from the above equations.

10.4.1 Advantages of Sequence Transformation

It is used when the network is balanced. For a n - node system a $3n \times 3n$ linear system solver

- $I^{abc} = Y^{abc} V^{abc}$ can

be decoupled into three $n \times n$ linear system solvers, $I_0 = Y_0 V_0$, $I_1 = Y_1 V_1$ and $I_2 = Y_2 V_2$. Hence it provides decoupling of the network.

- It can be applied for both balanced and unbalanced loads. However, simplicity and elegance of sequence component

approach reduces when network is unbalanced.

- Zero sequence current is used to provide sensitive earth fault detection technique.

10.5 Fault Current Calculation in Sequence Domain

Consider a transposed transmission line connected to an ideal voltage source E . The fault appears at the remote end of transmission line. We now derive sequence network interconnections for different fault types. We begin with a three phase fault.

10.5.1 Three phase fault: Three phase faults are considered to be symmetrical and hence sequence components are not

necessary for their calculation.

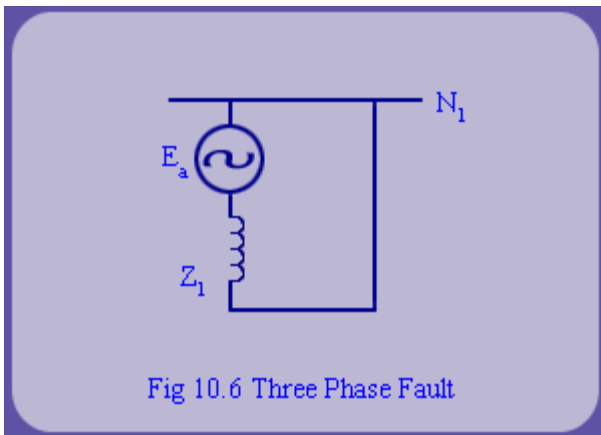

It can be easily shown that for a three phase fault, fault currents are balanced with,

$$I_2 = I_0 = 0 \text{ and } I_1 = I_a$$

(Hint : $I^{012} = T^{-1} I^{abc}$ with $I_b = a^2 I_a$ and $I_c = a I_a$).

Thus, for a Three Phase Fault only Positive Sequence Network is considered. The fault currents are given by the following equations

- $I_1 = \frac{E_a}{Z_1}$ (solid fault)
- $I_1 = \frac{E_a}{Z_1 + Z_f}$ (Fault through impedance Z_f)

10.5.2 Single Line to Ground Fault (SLG):

On an unloaded system (fig 10.7), let there be 'a' phase to ground fault with a fault impedance Z_f . Then, the faulted system is described by,

$I_a = I_f$, $I_b = 0$ and $I_c = 0$. Applying sequence transformation, we get

Thus, $I_0 = I_1 = I_2 = I_a/3$. Let V_f represent the voltage of the transmission line at the receiving end of the line where fault is created.

Further, from equation,

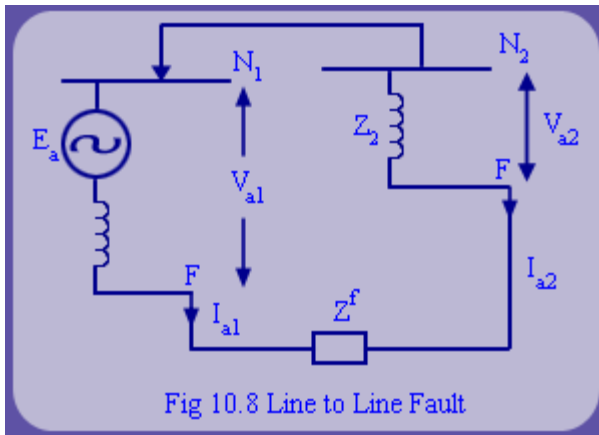

$$I_1 = -I_2 = \frac{E_a}{Z_1 + Z_2}$$

- $$I_1 = -I_2 = \frac{E_a}{Z_1 + Z_2 + Z_f}$$
 (fault through impedance Z_f)

- $$I_F = I_b = -I_c = (a^2 - a)I_1 = -j\sqrt{3}(I_1)$$

10.5 Fault Current Calculation in Sequence Domain (contd..)

10.5.3 Line to Line Ground Fault (LLG):

1. Bolted Fault:

- $$I_1 = \frac{E_a}{Z_1 + \frac{Z_2 Z_0}{Z_2 + Z_0}}$$

- $$I_2 = -I_1 \frac{Z_0}{Z_2 + Z_0}$$

- $$I_0 = -I_1 \frac{Z_2}{Z_2 + Z_0}$$

2. Fault current through impedance Z_f

- $$I_1 = \frac{E_a}{Z_1 + \frac{Z_f}{2} + \frac{\left(Z_2 + \frac{Z_f}{2}\right)\left(Z_0 + \frac{Z_f}{2} + 3Z_{FG}\right)}{Z_2 + Z_0 + Z_f + 3Z_{FG}}}$$

- $$I_2 = -I_1 \frac{\left(Z_0 + \frac{Z_f}{2} + 3Z_{FG}\right)}{Z_2 + Z_0 + Z_f + 3Z_{FG}}$$

- $$I_0 = -I_1 \frac{\left(Z_2 + \frac{Z_f}{2}\right)}{Z_2 + Z_0 + Z_f + 3Z_{FG}}$$

Fault current in phases b and c:

$$I_b = I_0 + a^2 I_{a1} + a I_{a2}$$

$$I_c = I_0 + a I_{a1} + a^2 I_{a2}$$

$$I_F = I_b + I_c = 3I_0$$

Z_f is fault impedance between the lines, while Z_{FG} is the fault impedance to Ground.

Review Questions

1. What are sequence components?
2. Derive the sequence transformation matrix using 'c' phase as reference phasor.
3. Show that sequence transformation is linear.
4. If Z_s is the self impedance and Z_m mutual impedance of a transmission line, show that $Z_0 = Z_s + 2Z_m$ and Z_1 and $Z_2 = Z_s - Z_m$.
5. Derive the equation for fault current in (a) L-L fault with fault impedance Z_f . (b) L-L-G fault.
6. If we do not want to lose information during a transformation 'f' from domain say A to B, then it is

required that 'f' should be invertible. In addition, to simplify analysis, we prefer linear transformations. List out some other transformations that you have come across in electrical engineering.

7. Clarke's transformation with 'a' phase as reference phasor is defined as follows:

$$\begin{bmatrix} I_0 \\ I_\alpha \\ I_\beta \end{bmatrix} = \frac{1}{3} \begin{bmatrix} 1 & 1 & 1 \\ 2 & -1 & -1 \\ 0 & \sqrt{3} & -\sqrt{3} \end{bmatrix} \begin{bmatrix} I_a \\ I_b \\ I_c \end{bmatrix}$$

Show that the transformation matrix is invertible. Hence, define the inverse transformation from Clarke's components to phase components.

8. Using Clarke's transformation show that

1) for a - g fault

$$I_\alpha = 2I_0$$

$$I_\beta = 0$$

2) b - c - g fault

$$I_\alpha = -I_0$$

3) b - c fault

$$I_\alpha = 0 \quad I_0 = 0$$

4) 3 - phase fault

$$I_0 = 0$$

9. Suppose that in an DSP implementation of relay, we have to choose between the sequence transformation and Clarke's transformation suggest your choice and justify it from computational requirement and ability to correctly detect a fault.

Recap

In this lecture we have learnt the following:

- Sources of fault current.
- Method to extract sequence components from unbalanced phasor.
- Advantages of sequence transformation.
- Derivation of sequence transformation matrix.
- Fault current formulae and interconnection of sequence network for three phase, S-L-G, L-L and L-L-G faults.

