

Digital Filter Banks

- The digital filter bank is set of bandpass filters with either a common input or a summed output
- An M -band analysis filter bank is shown below

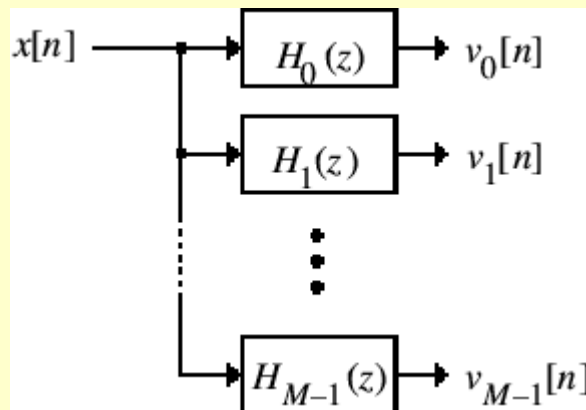

Digital Filter Banks

- The subfilters $H_k(z)$ in the analysis filter bank are known as analysis filters
- The analysis filter bank is used to decompose the input signal $x[n]$ into a set of subband signals $v_k[n]$ with each subband signal occupying a portion of the original frequency band

Digital Filter Banks

- An L -band synthesis filter bank is shown below

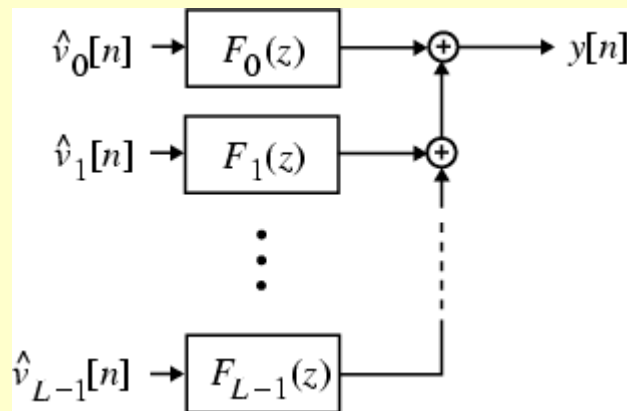

- It performs the dual operation to that of the analysis filter bank

Digital Filter Banks

- The subfilters $F_k(z)$ in the synthesis filter bank are known as synthesis filters
- The synthesis filter bank is used to combine a set of subband signals $\hat{v}_k[n]$ (typically belonging to contiguous frequency bands) into one signal $y[n]$ at its output

Uniform Digital Filter Banks

- A simple technique to design a class of filter banks with equal passband widths is outlined next
- Let $H_0(z)$ represent a causal lowpass digital filter with a real impulse response $h_0[n]$:

$$H_0(z) = \sum_{n=-\infty}^{\infty} h_0[n]z^{-n}$$

- The filter $H_0(z)$ is assumed to be an IIR filter without any loss of generality

Uniform Digital Filter Banks

- Assume that $H_0(z)$ has its passband edge ω_p and stopband edge ω_s around π/M , where M is some arbitrary integer, as indicated below

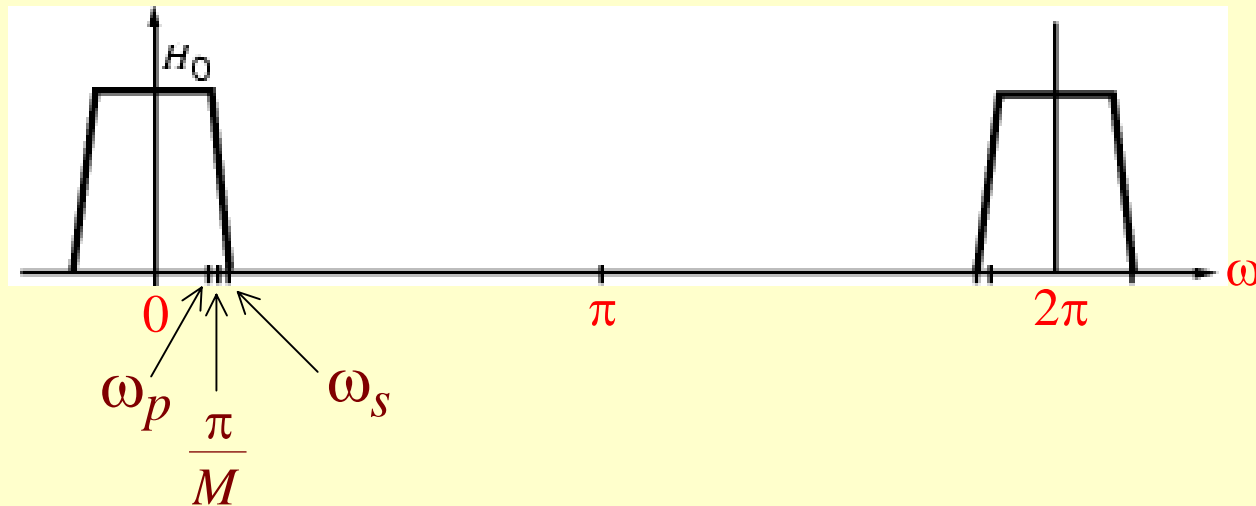

Uniform Digital Filter Banks

- Now, consider the transfer function $H_k(z)$ whose impulse response $h_k[n]$ is given by

$$h_k[n] = h_0[n] e^{j2\pi kn/M} = h_0[n] W_M^{-kn},$$

$$0 \leq k \leq M - 1$$

where we have used the notation $W_M = e^{-j2\pi/M}$

- Thus,

$$H_k(z) = \sum_{n=-\infty}^{\infty} h_k[n] z^{-n} = \sum_{n=-\infty}^{\infty} h_0[n] \left(z W_M^k \right)^{-n},$$

$$0 \leq k \leq M - 1$$

Uniform Digital Filter Banks

- i.e.,

$$H_k(z) = H_0(zW_M^k), \quad 0 \leq k \leq M - 1$$

- The corresponding frequency response is given by

$$H_k(e^{j\omega}) = H_0(e^{j(\omega - 2\pi k/M)}), \quad 0 \leq k \leq M - 1$$

- Thus, the frequency response of $H_k(z)$ is obtained by shifting the response of $H_0(z)$ to the right by an amount $2\pi k/M$

Uniform Digital Filter Banks

- The responses of $H_0(z)$, $H_1(z)$, \dots , $H_{M-1}(z)$ are shown below

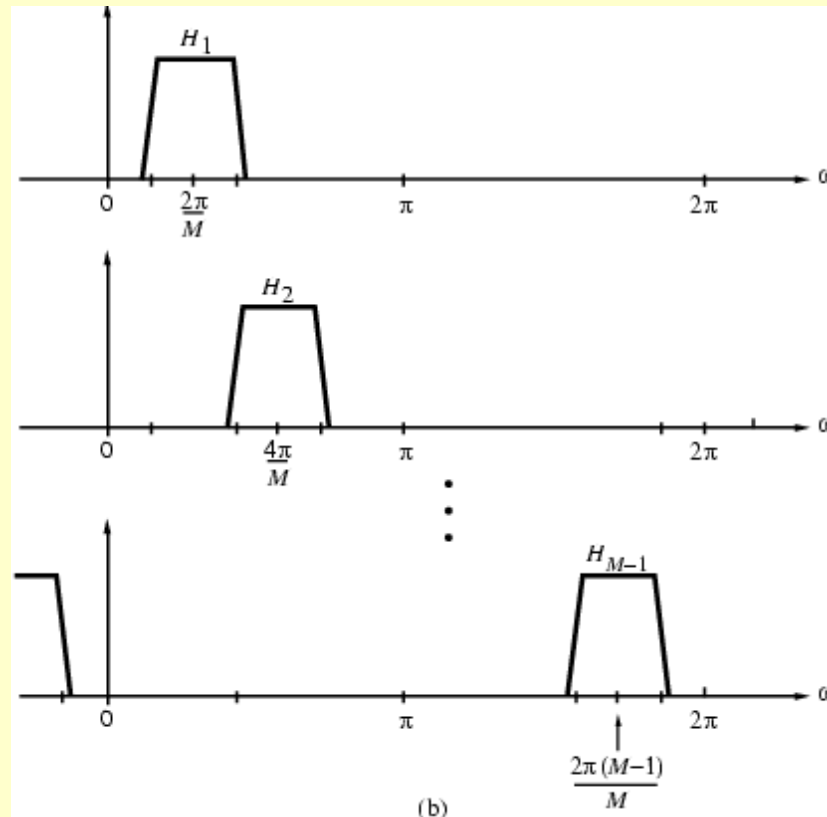

Uniform Digital Filter Banks

- Note: The impulse responses $h_k[n]$ are, in general complex, and hence $|H_k(e^{j\omega})|$ does not necessarily exhibit symmetry with respect to $\omega = 0$
- The responses shown in the figure of the previous slide can be seen to be uniformly shifted version of the response of the basic prototype filter $H_0(z)$

Uniform Digital Filter Banks

- The M filters defined by

$$H_k(z) = H_0(zW_M^k), \quad 0 \leq k \leq M - 1$$

could be used as the analysis filters in the analysis filter bank or as the synthesis filters in the synthesis filter bank

- Since the magnitude responses of all M filters are uniformly shifted version of that of the prototype filter, the filter bank obtained is called a uniform filter bank

Uniform DFT Filter Banks

Polyphase Implementation

- Let the prototype lowpass transfer function be represented in its M -band polyphase form:

$$H_0(z) = \sum_{\ell=0}^{M-1} z^{-\ell} E_{\ell}(z^M)$$

where $E_{\ell}(z)$ is the ℓ -th polyphase component of $H_0(z)$:

$$E_{\ell}(z) = \sum_{n=0}^{\infty} e_{\ell}[n]z^{-n} = \sum_{n=0}^{\infty} h_0[\ell + nM]z^{-n},$$

$$0 \leq \ell \leq M - 1$$

Uniform DFT Filter Banks

- Substituting z with zW_M^k in the expression for $H_0(z)$ we arrive at the M -band polyphase decomposition of $H_k(z)$:

$$\begin{aligned} H_k(z) &= \sum_{\ell=0}^{M-1} z^{-\ell} W_M^{-k\ell} E_{\ell}(z^M W_M^{kM}) \\ &= \sum_{\ell=0}^{M-1} z^{-\ell} W_M^{-k\ell} E_{\ell}(z^M), \quad 0 \leq k \leq M-1 \end{aligned}$$

- In deriving the last expression we have used the identity $W_M^{kM} = 1$

Uniform DFT Filter Banks

- The equation on the previous slide can be written in matrix form as

$$H_k(z) = [1 \quad W_M^{-k} \quad W_M^{-2k} \quad \dots \quad W_M^{-(M-1)k}] \begin{bmatrix} E_0(z^M) \\ z^{-1} E_1(z^M) \\ z^{-2} E_2(z^M) \\ \vdots \\ z^{-(M-1)} E_{M-1}(z^M) \end{bmatrix}$$

$$0 \leq k \leq M - 1$$

Uniform DFT Filter Banks

- All M equations on the previous slide can be combined into one matrix equation as

$$\begin{bmatrix} H_0(z) \\ H_1(z) \\ H_2(z) \\ \vdots \\ H_{M-1}(z) \end{bmatrix} = \underbrace{\begin{bmatrix} 1 & 1 & 1 & \dots & 1 \\ 1 & W_M^{-1} & W_M^{-2} & \dots & W_M^{-(M-1)} \\ 1 & W_M^{-2} & W_M^{-4} & \dots & W_M^{-2(M-1)} \\ \vdots & \vdots & \vdots & \ddots & \vdots \\ 1 & W_M^{-(M-1)} & W_M^{-2(M-1)} & \dots & W_M^{-(M-1)^2} \end{bmatrix}}_{M \mathbf{D}^{-1}} \begin{bmatrix} E_0(z^M) \\ z^{-1} E_1(z^M) \\ z^{-2} E_2(z^M) \\ \vdots \\ z^{-(M-1)} E_{M-1}(z^M) \end{bmatrix}$$

- In the above \mathbf{D} is the $M \times M$ DFT matrix

Uniform DFT Filter Banks

- An efficient implementation of the M -band uniform analysis filter bank, more commonly known as the uniform DFT analysis filter bank, is then as shown below

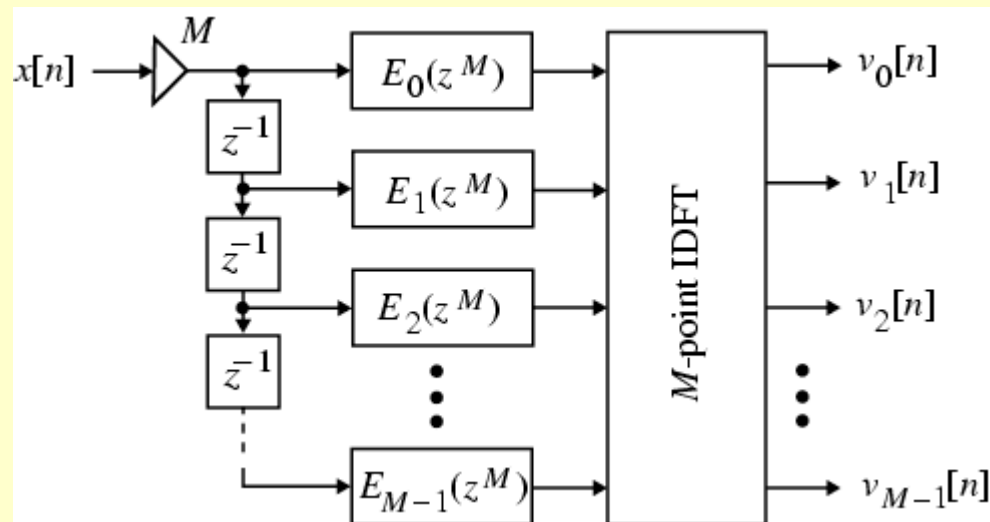

Uniform DFT Filter Banks

- The computational complexity of an M -band uniform DFT filter bank is much smaller than that of a direct implementation as shown below

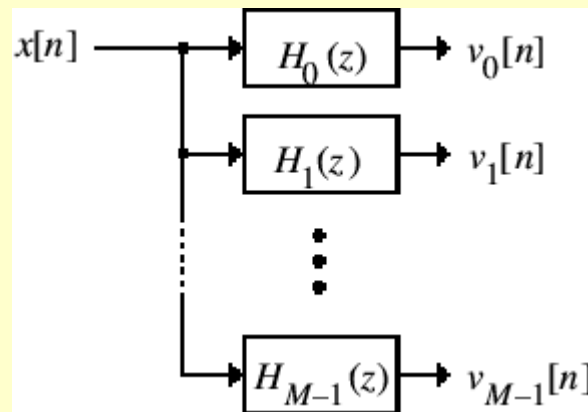

Uniform DFT Filter Banks

- For example, an M -band uniform DFT analysis filter bank based on an N -tap prototype lowpass filter requires a total of $\frac{M}{2} \log_2 M + N$ multipliers
- On the other hand, a direct implementation requires NM multipliers

Uniform DFT Filter Banks

- Following a similar development, we can derive the structure for a **uniform DFT synthesis filter bank** as shown below

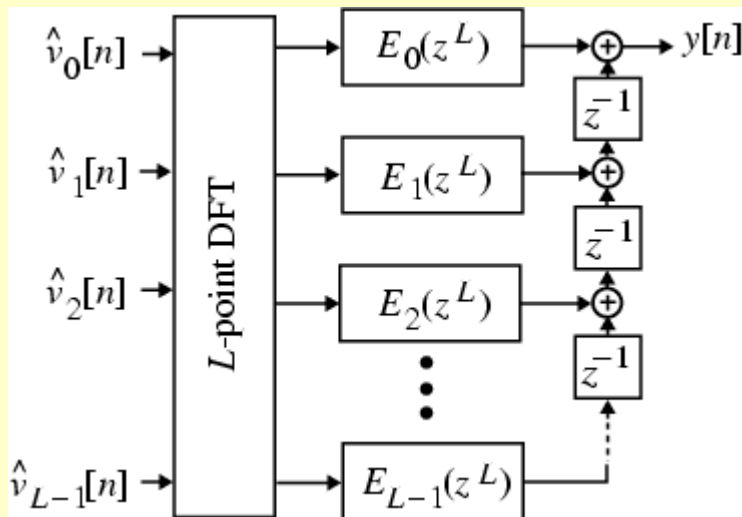

Type I uniform DFT synthesis filter bank

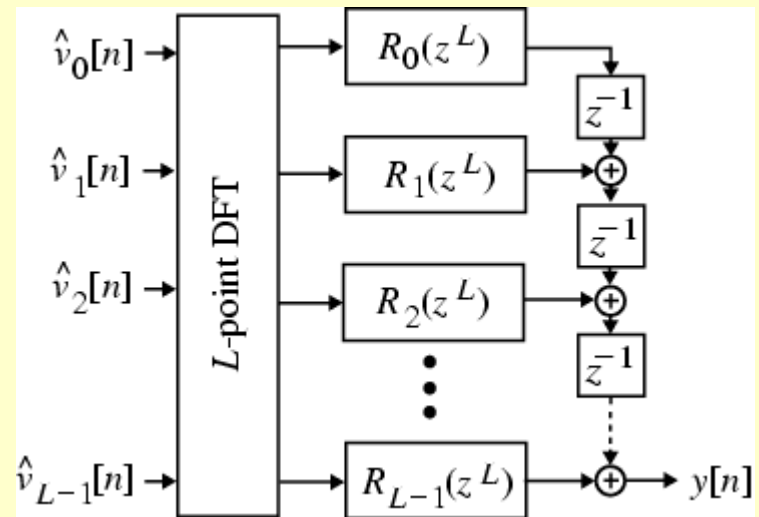

Type II uniform DFT synthesis filter bank

Uniform DFT Filter Banks

- Now $E_i(z^M)$ can be expressed in terms of

$$\begin{bmatrix} E_0(z^M) \\ z^{-1}E_1(z^M) \\ z^{-2}E_2(z^M) \\ \vdots \\ z^{-(M-1)}E_{M-1}(z^M) \end{bmatrix} = \frac{1}{M} \mathbf{D} \begin{bmatrix} H_0(z) \\ H_1(z) \\ H_2(z) \\ \vdots \\ H_{M-1}(z) \end{bmatrix}$$

- The above equation can be used to determine the polyphase components of an IIR transfer function $H_0(z)$

Nyquist Filters

- Under certain conditions, a lowpass filter can be designed to have a number of zero-valued coefficients
- When used as interpolation filters these filters preserve the nonzero samples of the up-sampler output at the interpolator output
- Moreover, due to the presence of these zero-valued coefficients, these filters are computationally more efficient than other lowpass filters of same order

L th-Band Filters

- These filters, called the Nyquist filters or L th-band filters, are often used in single-rate and multi-rate signal processing
- Consider the factor-of- L interpolator shown below

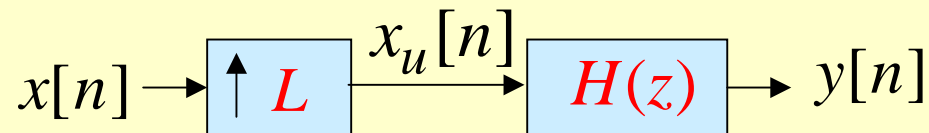

- The input-output relation of the interpolator in the z -domain is given by

$$Y(z) = H(z)X(z^L)$$

L th-Band Filters

- If $H(z)$ is realized in the L -band polyphase form, then we have

$$H(z) = \sum_{i=0}^{L-1} z^{-i} E_i(z^L)$$

- Assume that the k -th polyphase component of $H(z)$ is a constant, i.e., $E_k(z) = \alpha$:

$$H(z) = E_0(z^L) + z^{-1} E_1(z^L) + \dots + z^{-(k-1)} E_{k-1}(z^L) \\ + z^{-(k+1)} E_{k+1}(z^L) + \dots + z^{-(L-1)} E_{L-1}(z^L)$$

Lth-Band Filters

- Then we can express $Y(z)$ as

$$Y(z) = \alpha z^{-k} X(z^L) + \sum_{\substack{\ell=0 \\ \ell \neq k}}^{L-1} z^{-\ell} E_{\ell}(z^L) X(z^L)$$

- As a result,

$$y[Ln + k] = \alpha x[n]$$

- Thus, the input samples appear at the output without any distortion for all values of n , whereas, in-between $(L-1)$ output samples are determined by interpolation

*L*th-Band Filters

- A filter with the above property is called a Nyquist filter or an *L*th-band filter
- Its impulse response has many zero-valued samples, making it computationally attractive
- For example, the impulse response of an *L*th-band filter for $k = 0$ satisfies the following condition

$$h[Ln] = \begin{cases} \alpha, & n = 0 \\ 0, & \text{otherwise} \end{cases}$$

Lth-Band Filters

- Figure below shows a typical impulse response of a third-band filter ($L = 3$)

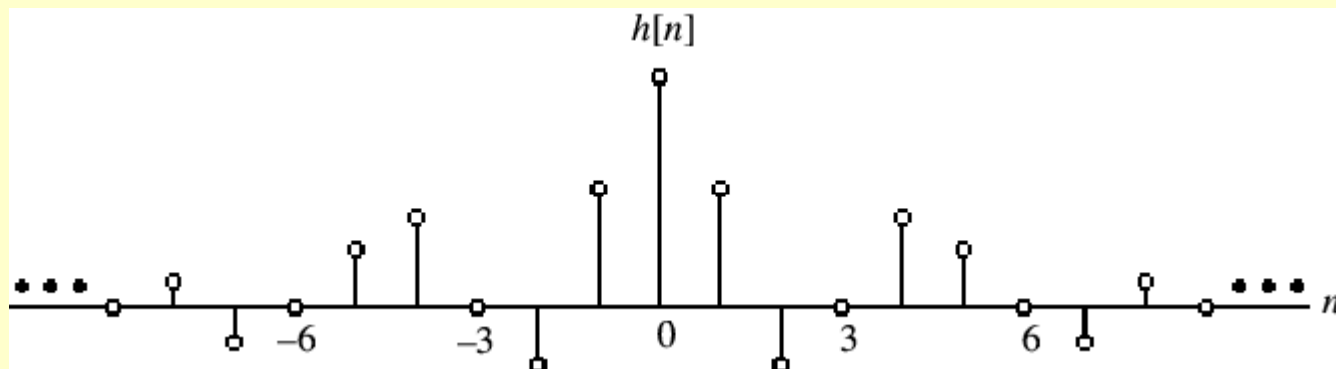

- L th-band filters can be either FIR or IIR filters

Lth-Band Filters

- If the 0-th polyphase component of $H(z)$ is a constant, i.e., $E_0(z) = \alpha$ then it can be shown that

$$\sum_{k=0}^{L-1} H(zW_L^k) = L\alpha = 1 \quad (\text{assuming } \alpha = 1/L)$$

- Since the frequency response of $H(zW_L^k)$ is the shifted version $H(e^{j(\omega-2\pi k/L)})$ of $H(e^{j\omega})$, the sum of all of these L uniformly shifted versions of $H(e^{j\omega})$ add up to a constant

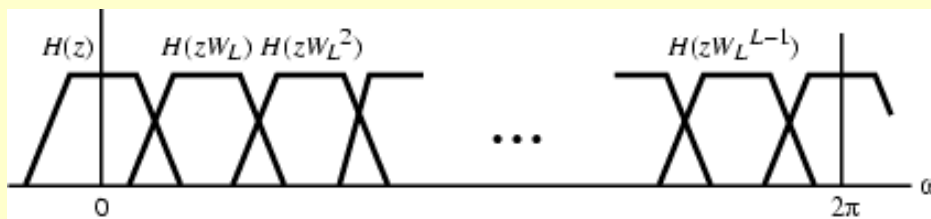

Half-Band Filters

- An L th-band filter for $L = 2$ is called a half-band filter
- The transfer function of a half-band filter is thus given by

$$H(z) = \alpha + z^{-1}E_1(z^2)$$

with its impulse response satisfying

$$h[2n] = \begin{cases} \alpha, & n = 0 \\ 0, & \text{otherwise} \end{cases}$$

Half-Band Filters

- The condition

$$H(z) = \alpha + z^{-1}E_1(z^2)$$

reduces to

$$H(z) + H(-z) = 1 \quad (\text{assuming } \alpha = 0.5)$$

- If $H(z)$ has real coefficients, then

$$H(-e^{j\omega}) = H(e^{j(\pi-\omega)})$$

- Hence

$$H(e^{j\omega}) + H(e^{j(\pi-\omega)}) = 1$$

Half-Band Filters

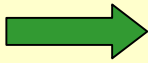
-  $H(e^{j(\pi/2-\theta)})$ and $H(e^{j(\pi/2+\theta)})$ add up to 1 for all θ
- Or, in other words, $H(e^{j\omega})$ exhibits a symmetry with respect to the half-band frequency $\pi/2$, hence the name “half-band filter”

Half-Band Filters

- Figure below illustrates this symmetry for a half-band lowpass filter for which passband and stopband ripples are equal, i.e., $\delta_p = \delta_s$ and passband and stopband edges are symmetric with respect to $\pi/2$, i.e., $\omega_p + \omega_s = \pi$

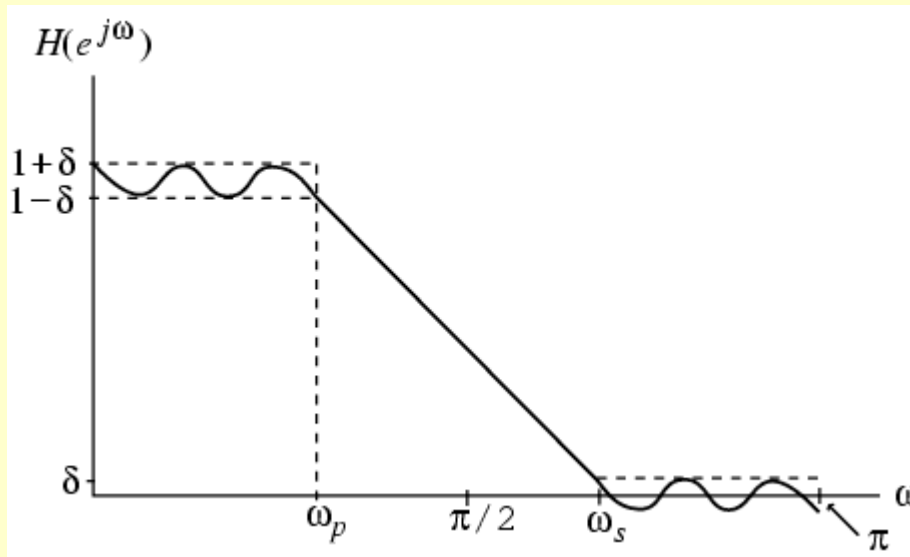

Half-Band Filters

- Attractive property: About 50% of the coefficients of $h[n]$ are zero
- This reduces the number of multiplications required in its implementation significantly
- For example, if $N = 101$, an arbitrary Type 1 FIR transfer function requires about 50 multipliers, whereas, a Type 1 half-band filter requires only about 25 multipliers

Half-Band Filters

- An FIR half-band filter can be designed with linear phase
- However, there is a constraint on its length
- Consider a zero-phase half-band FIR filter for which $h[n] = \alpha * h[-n]$, with $|\alpha| = 1$
- Let the highest nonzero coefficient be $h[R]$

Half-Band Filters

- Then R is odd as a result of the condition

$$h[2n] = \begin{cases} \alpha, & n = 0 \\ 0, & \text{otherwise} \end{cases}$$

- Therefore $R = 2K+1$ for some integer K
- Thus the length of $h[n]$ is restricted to be of the form $2R+1 = 4K+3$ [unless $H(z)$ is a constant]

Design of Linear-Phase L th-Band Filters

- A lowpass linear-phase L th-band FIR filter can be readily designed via the windowed Fourier series approach
- In this approach, the impulse response coefficients of the lowpass filter are chosen as $h[n] = h_{LP}[n] \cdot w[n]$ where $h_{LP}[n]$ is the impulse response of an ideal lowpass filter with a cutoff at π/L and $w[n]$ is a suitable window function

Design of Linear-Phase L th-Band Filters

- Now, the impulse response of an ideal L th-band lowpass filter with a cutoff at $\omega_c = \pi/L$ is given by

$$h_{LP}[n] = \frac{\sin(\pi n / L)}{\pi n}, \quad -\infty \leq n \leq \infty$$

- It can be seen from the above that

$$h_{LP}[n] = 0 \quad \text{for } n = \pm L, \pm 2L, \dots$$

Design of Linear-Phase L th-Band Filters

- Hence, the coefficient condition of the L th-band filter

$$h[Ln] = \begin{cases} \alpha, & n = 0 \\ 0, & \text{otherwise} \end{cases}$$

is indeed satisfied

- Hence, an L th-band FIR filter can be designed by applying a suitable window $w[n]$ to $h_{LP}[n]$

Design of Linear-Phase L th-Band Filters

- There are many other candidates for L th-band FIR filters
- Program 10_8 can be used to design an L th-band FIR filter using the windowed Fourier series approach
- The program employs the Hamming window
- However, other windows can also be used

Design of Linear-Phase L th-Band Filters

- Figure below shows the gain response of a half-band filter of length-23 designed using Program 10_8

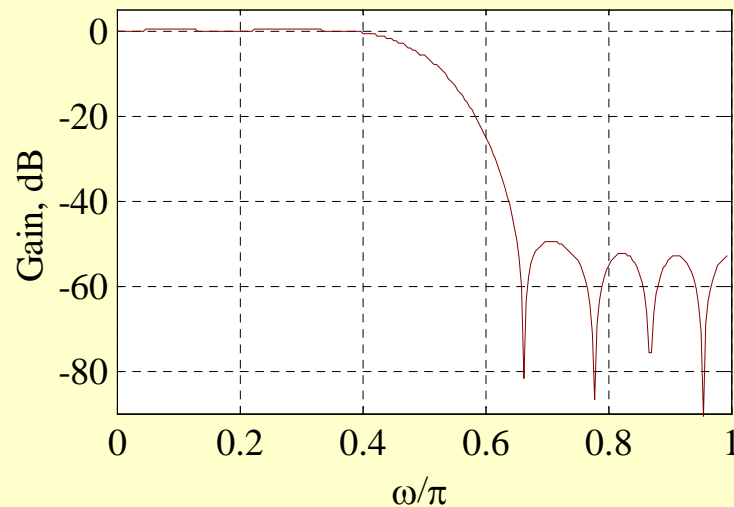

Design of Linear-Phase L th-Band Filters

- The filter coefficients are given by

$$h[-11]=h[11]=-0.002315; \quad h[-10]=h[10]=0;$$

$$h[-9]=h[9]=0.005412; \quad h[-8]=h[8]=0;$$

$$h[-7]=h[7]=-0.001586; \quad h[-6]=h[6]=0;$$

$$h[-5]=h[5]=0.003584; \quad h[-4]=h[4]=0;$$

$$h[-3]=h[3]=-0.089258; \quad h[-2]=h[2]=0;$$

$$h[-1]=h[1]=0.3122379; \quad h[0]=0.5;$$

- As expected, $h[n] = 0$ for

$$n = \pm 2, \pm 4, \pm 6, \pm 8, \pm 10$$