

First Course on Power Systems

Module 8: Synchronous Generators

By
Ned Mohan
Professor of ECE
University of Minnesota

Reference Textbook:
First Course on Power Systems by Ned Mohan,
www.mnpere.com

Module 8: Synchronous Generators

Chapter 9	SYNCHRONOUS GENERATORS	9-1
9-1	INTRODUCTION	9-1
9-2	STRUCTURE	9-2
9-3	INDUCED-EMF IN THE STATOR WINDINGS	9-4
9-4	POWER OUTPUT, STABILITY AND THE LOSS OF SYNCHRONISM	9-9
9-5	FIELD EXCITATION CONTROL TO ADJUST REACTIVE POWER	9-11
9-6	FIELD EXCITERS FOR AUTOMATIC VOLTAGE REGULATION (AVR)	9-12
9-7	SYNCHRONOUS, TRANSIENT AND SUB-TRANSIENT REACTANCES	9-13
	REFERENCES	9-15
	PROBLEMS	9-15

Synchronous Generators

- Very Important Apparatus in Power Systems
- Supply Reactive Power

Use of Synchronous Generators

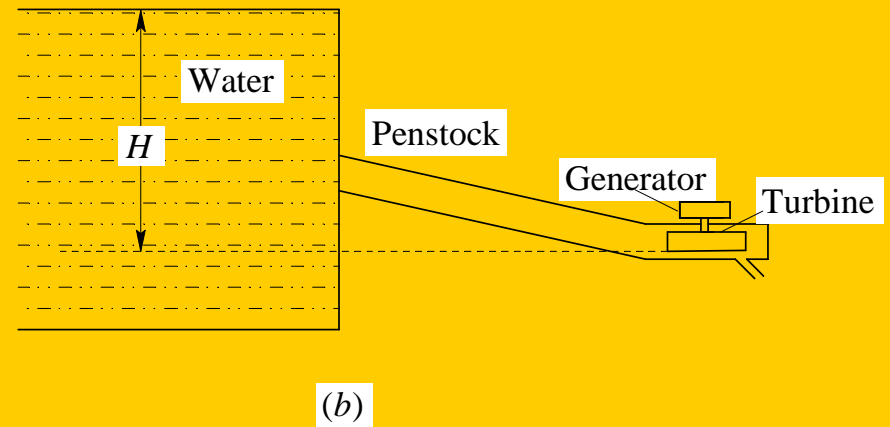
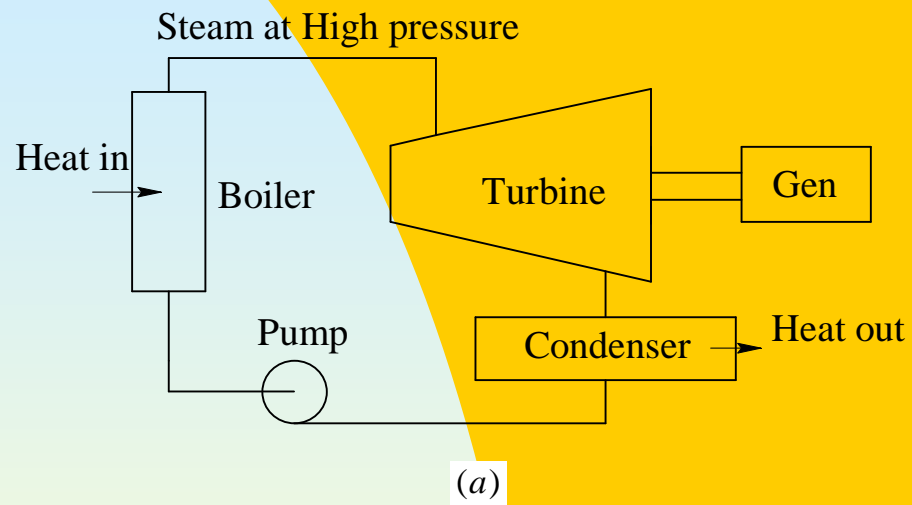

Cross-section of Synchronous Generators

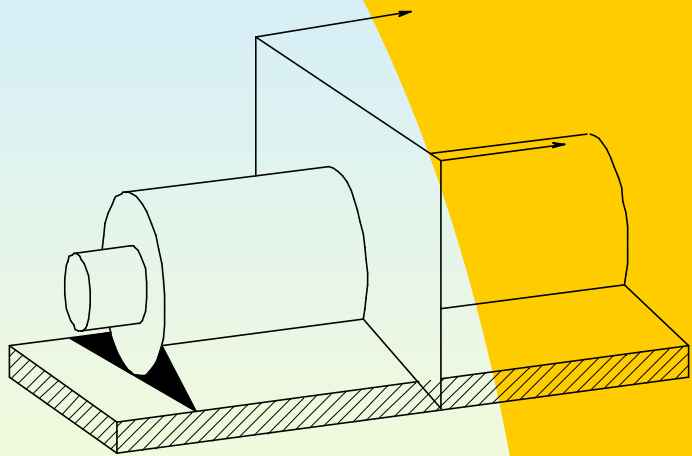

(a)

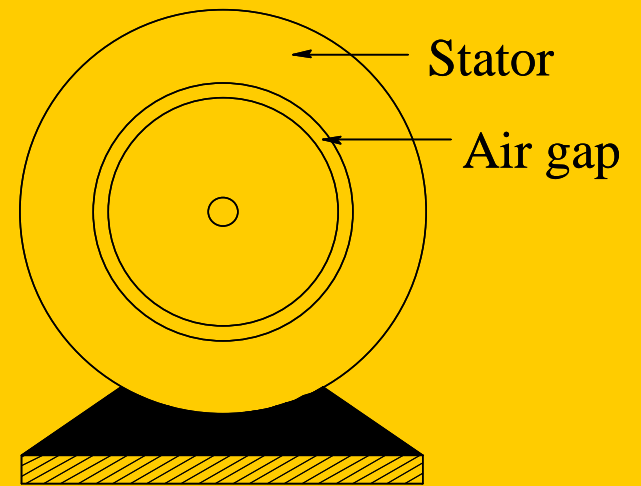

(b)

Synchronous Generator Structure

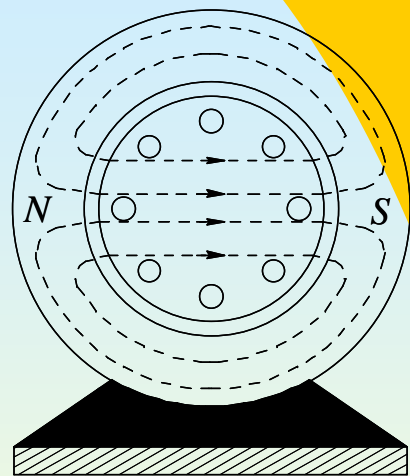

(a)

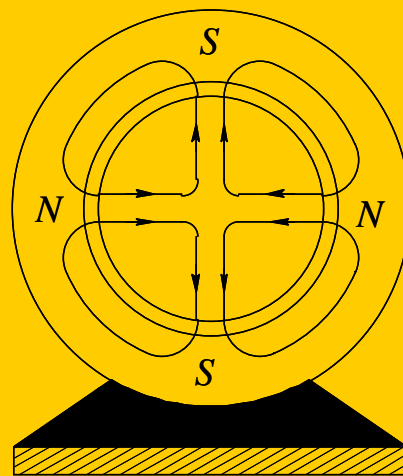

(b)

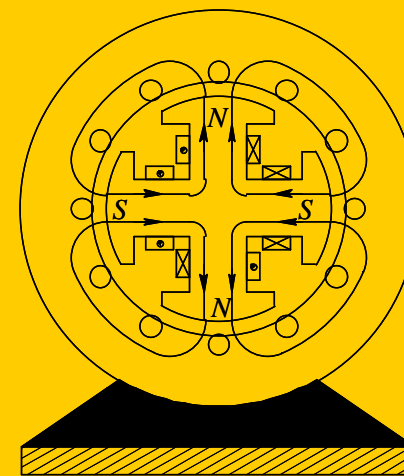

(c)

Sinusoidally-Distributed Windings

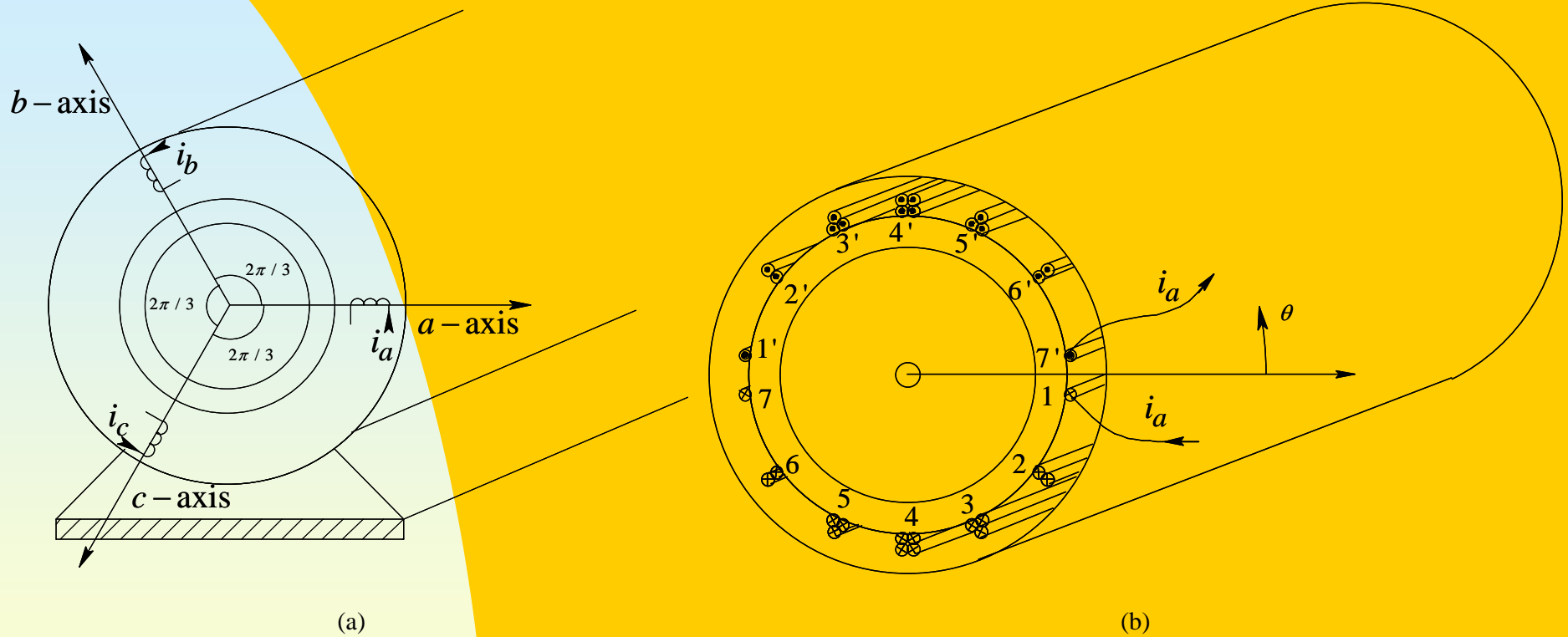

Three-Phase Winding Connection in a Wye

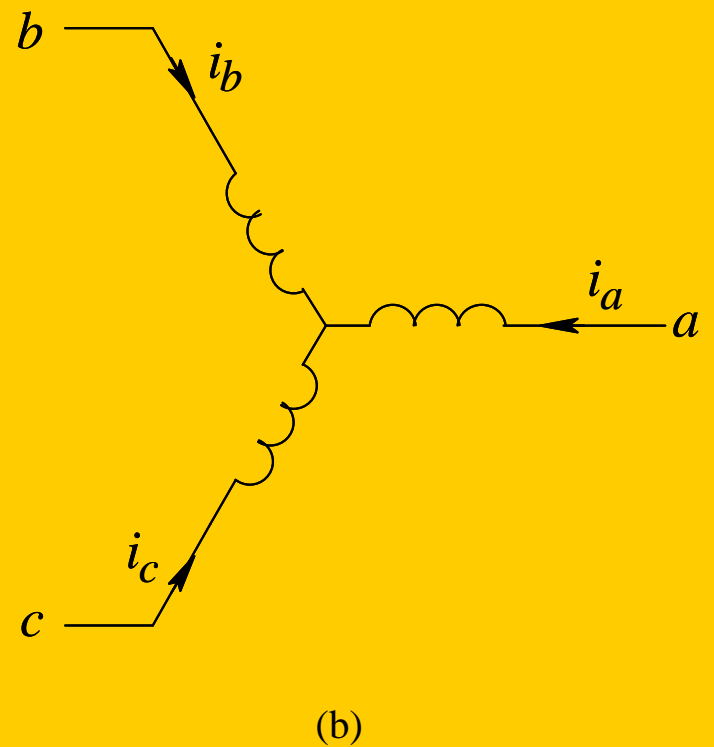
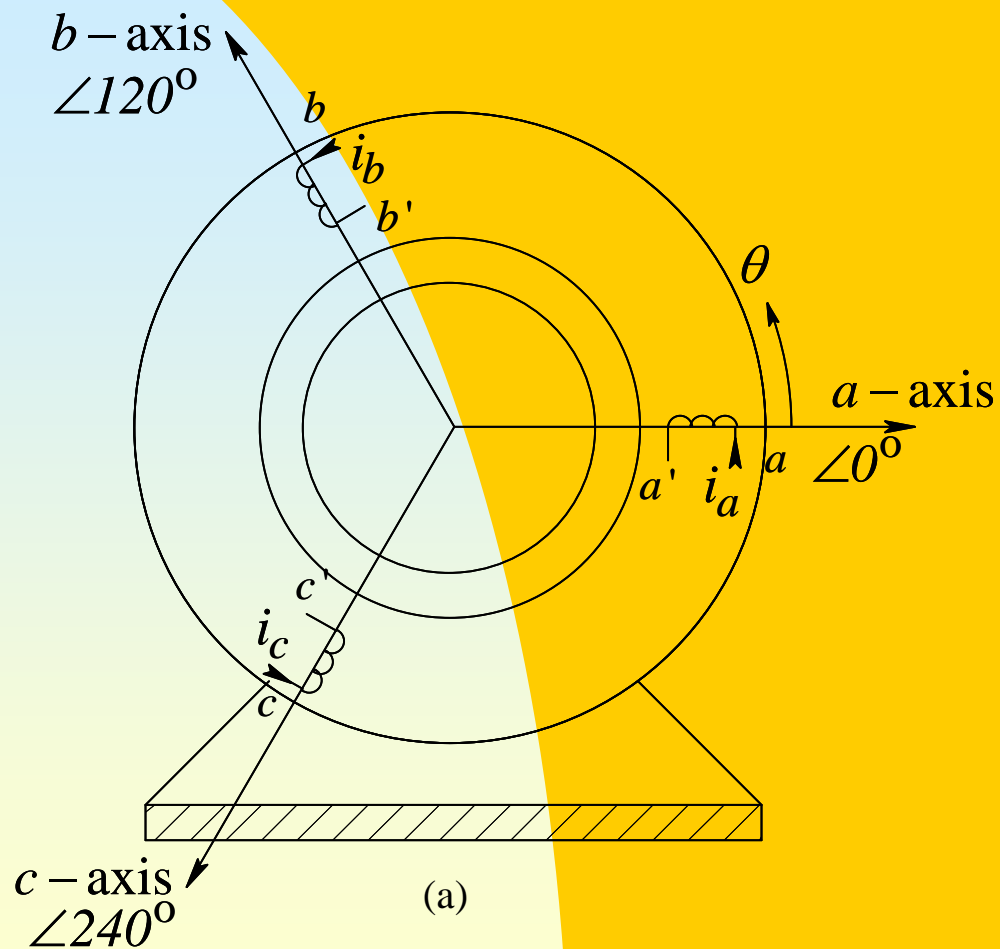

Synchronous Generator Rotor Field

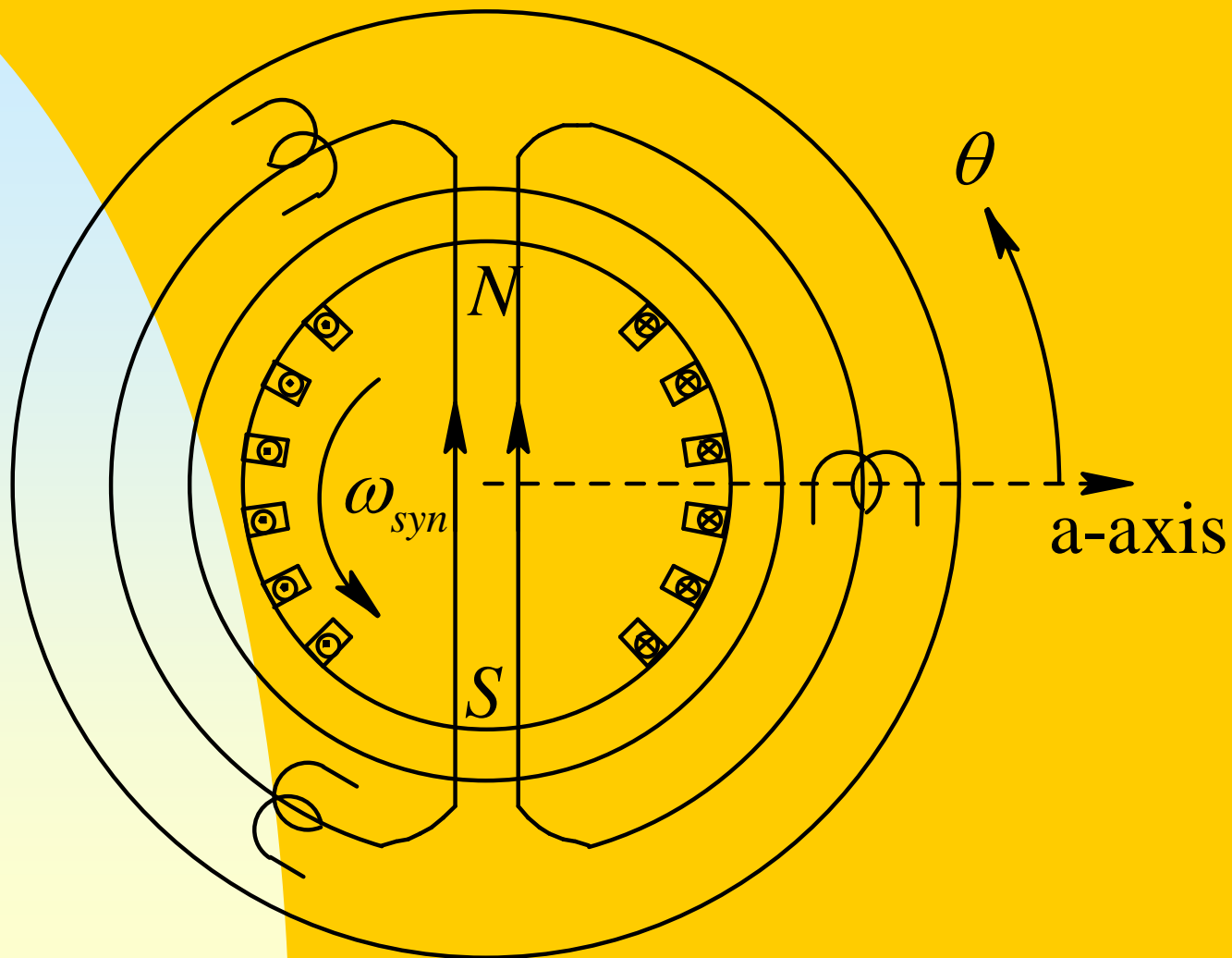

Voltage induced in the Stator Phase due to Rotating Rotor Field

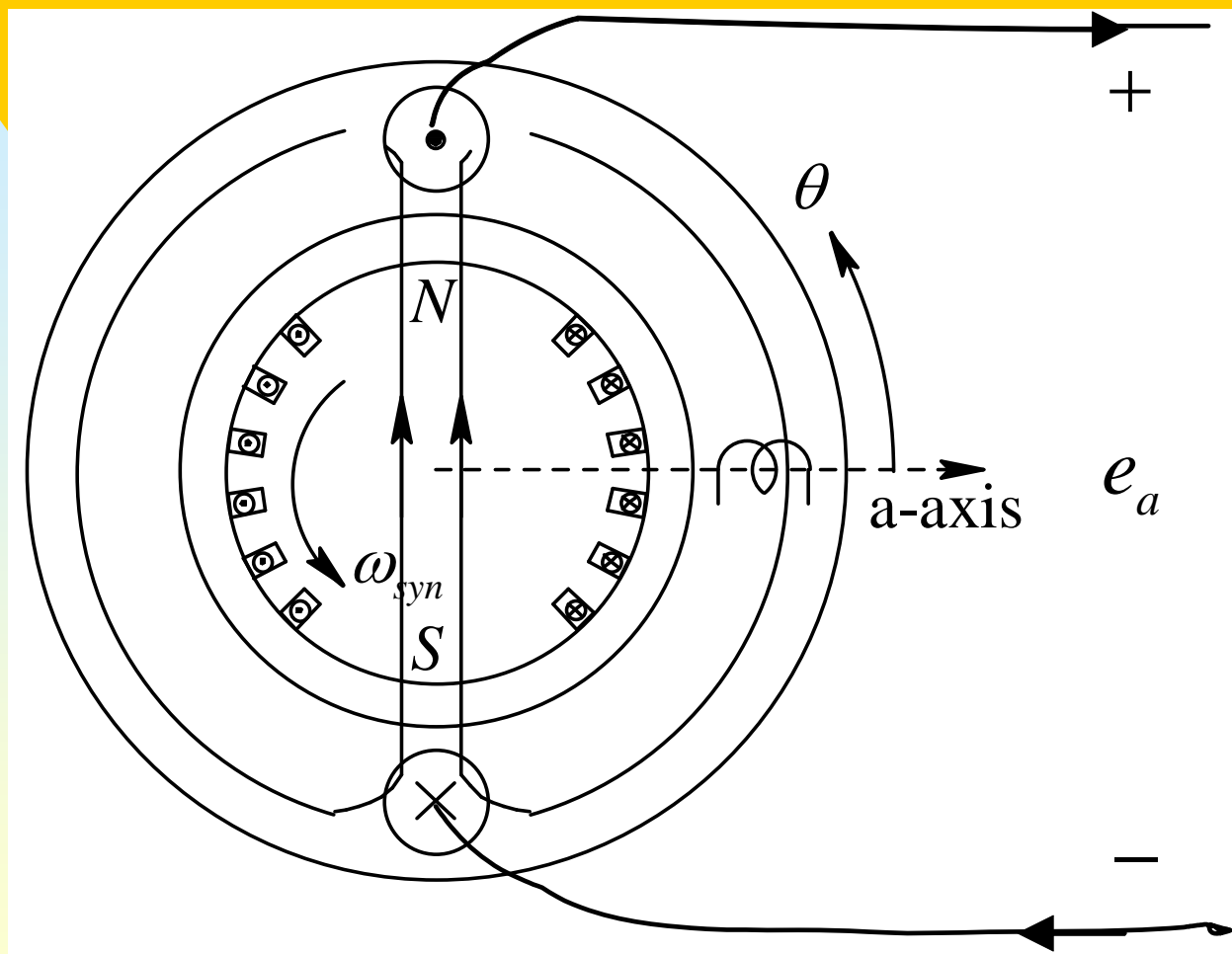

Fig. 9-7 Current direction and voltage polarities; the rotor position shown induces

maximum e_a .