

Synthesis of Three-Phase AC

- Applications:
 - Electric Drives
 - UPS
 - PV Systems
 - Power Systems

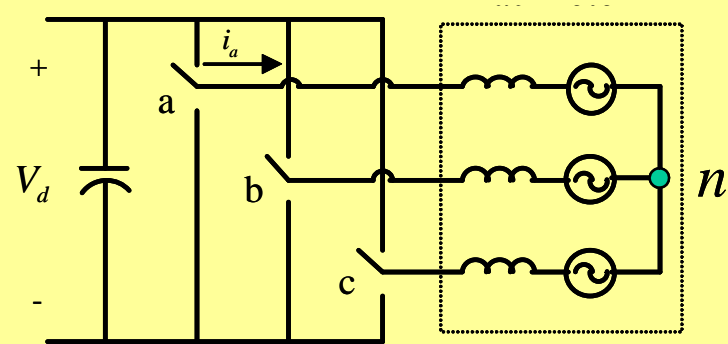

Synthesis of Low-Frequency AC:

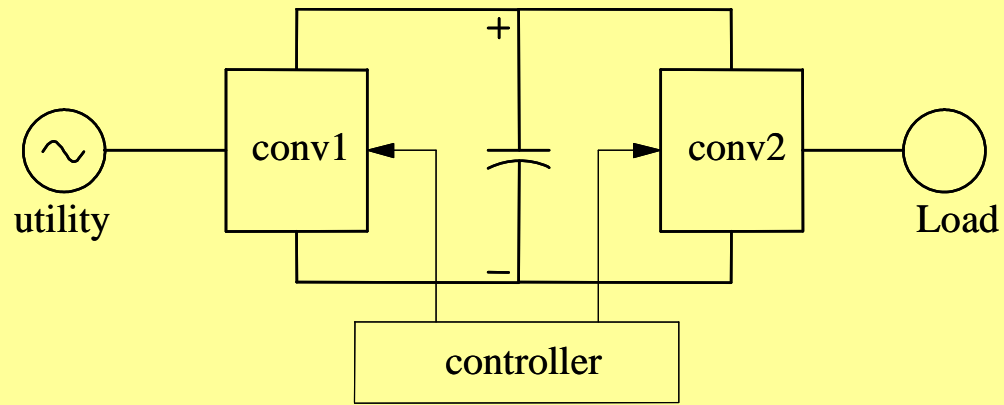
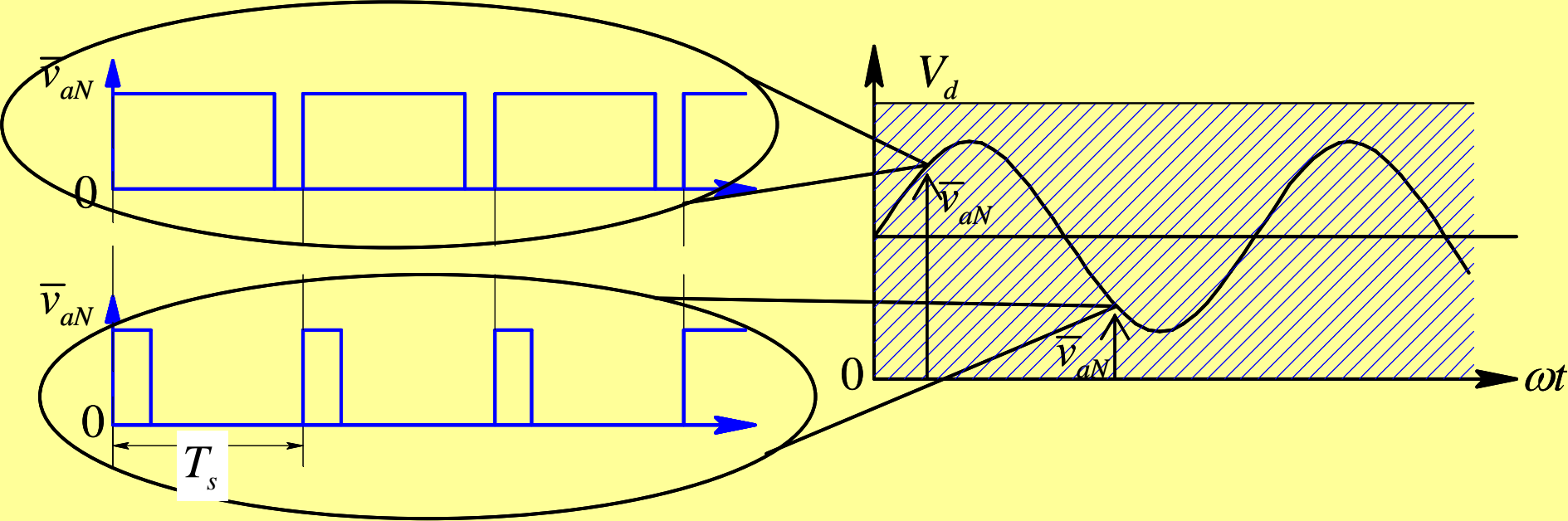

Three-Phase Inverters

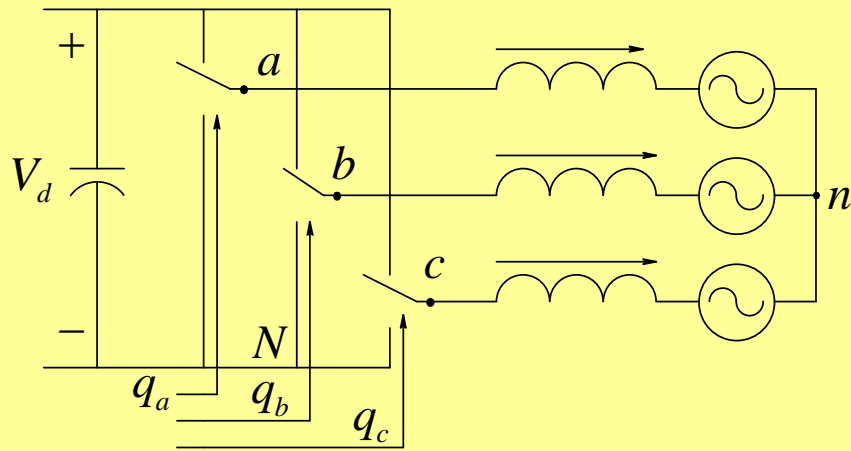

(a)

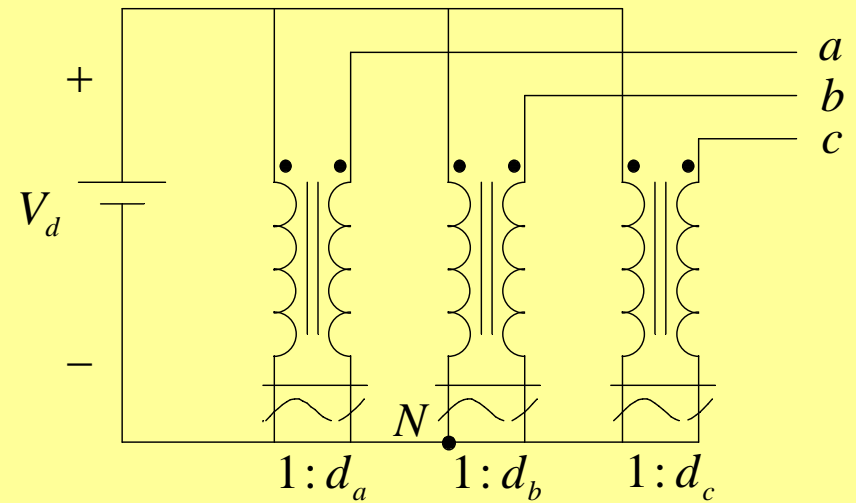

(b)

Superposition -

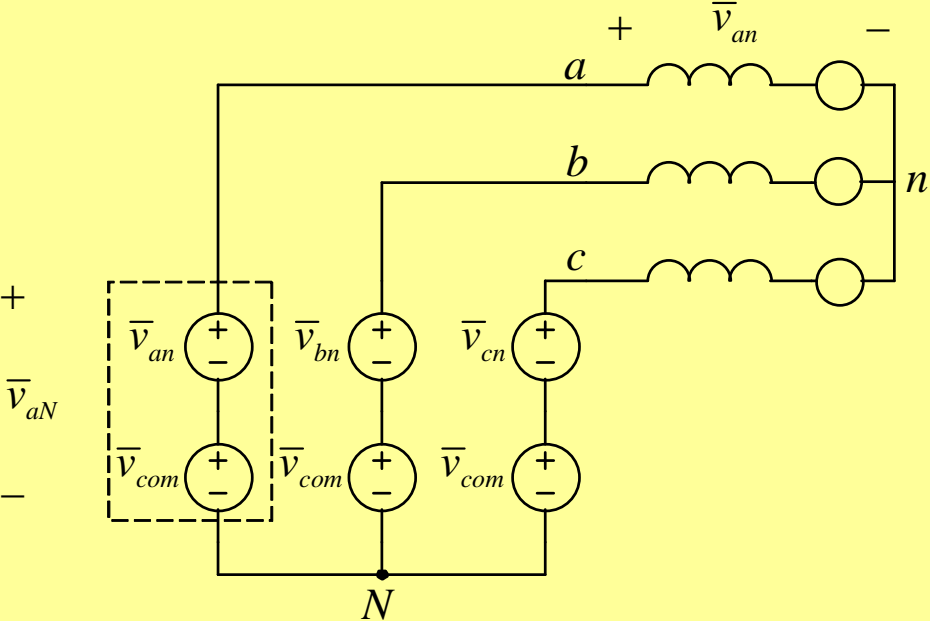

(a)

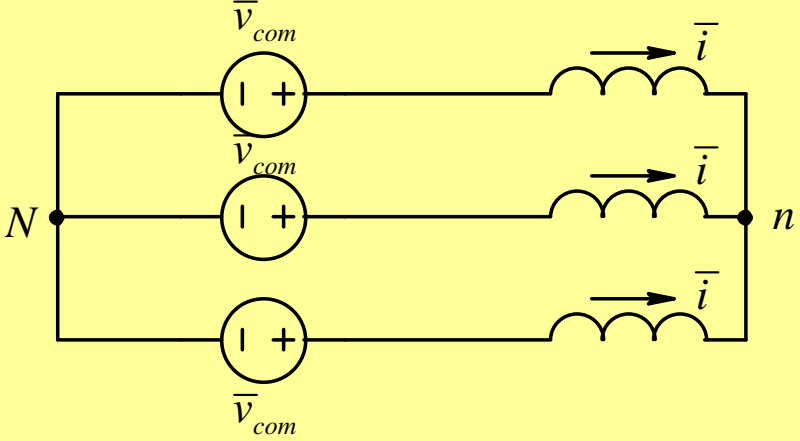

(b)

Sine PWM

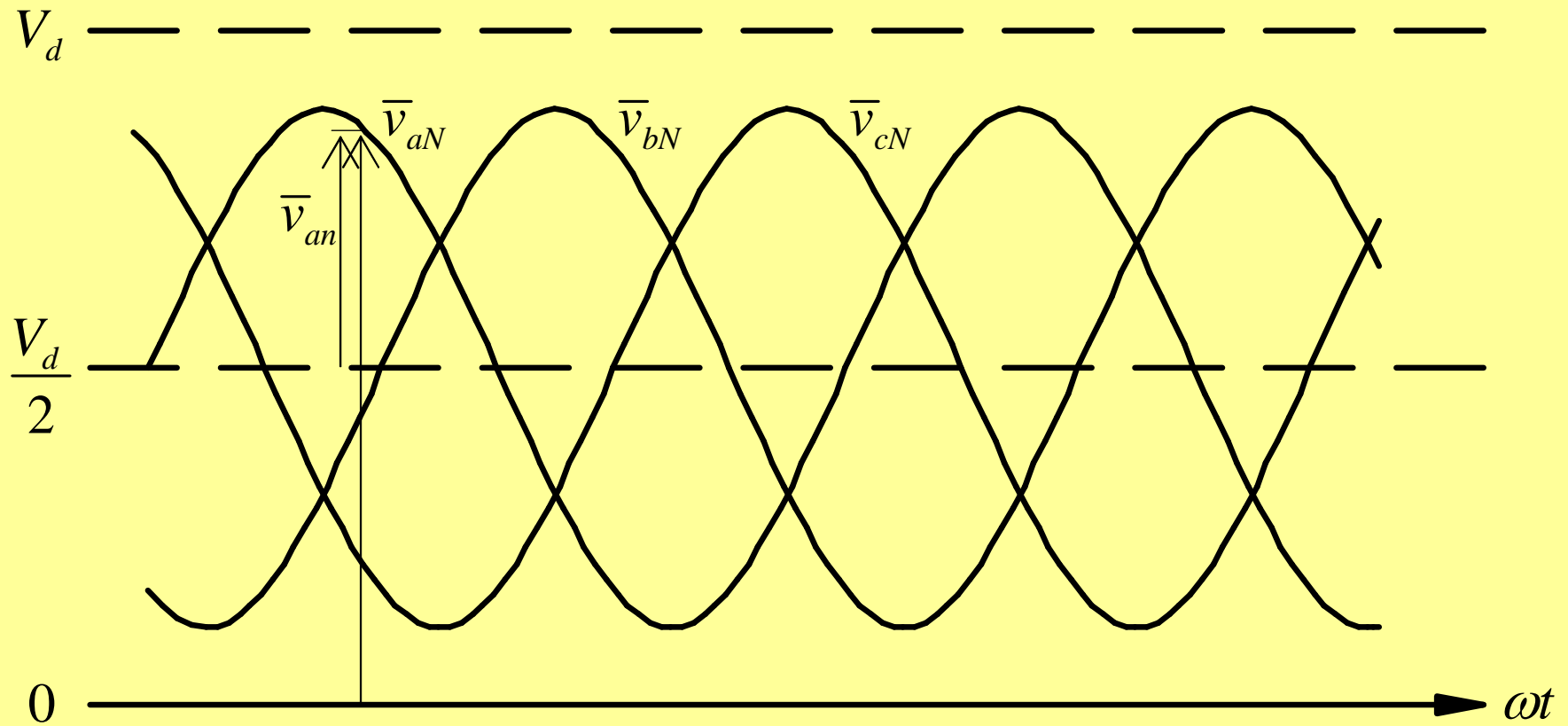

Waveforms

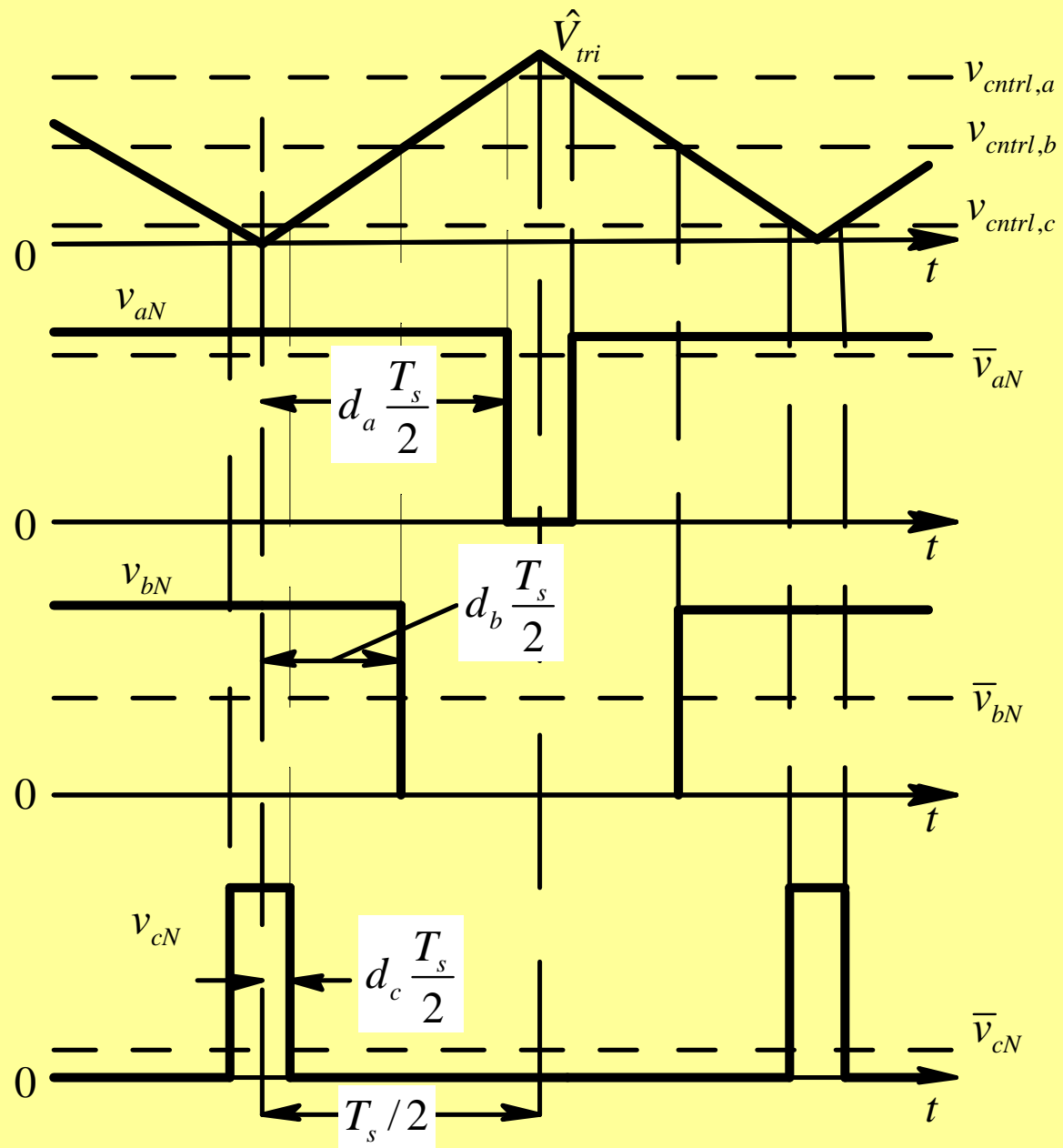

PSpice Modeling:

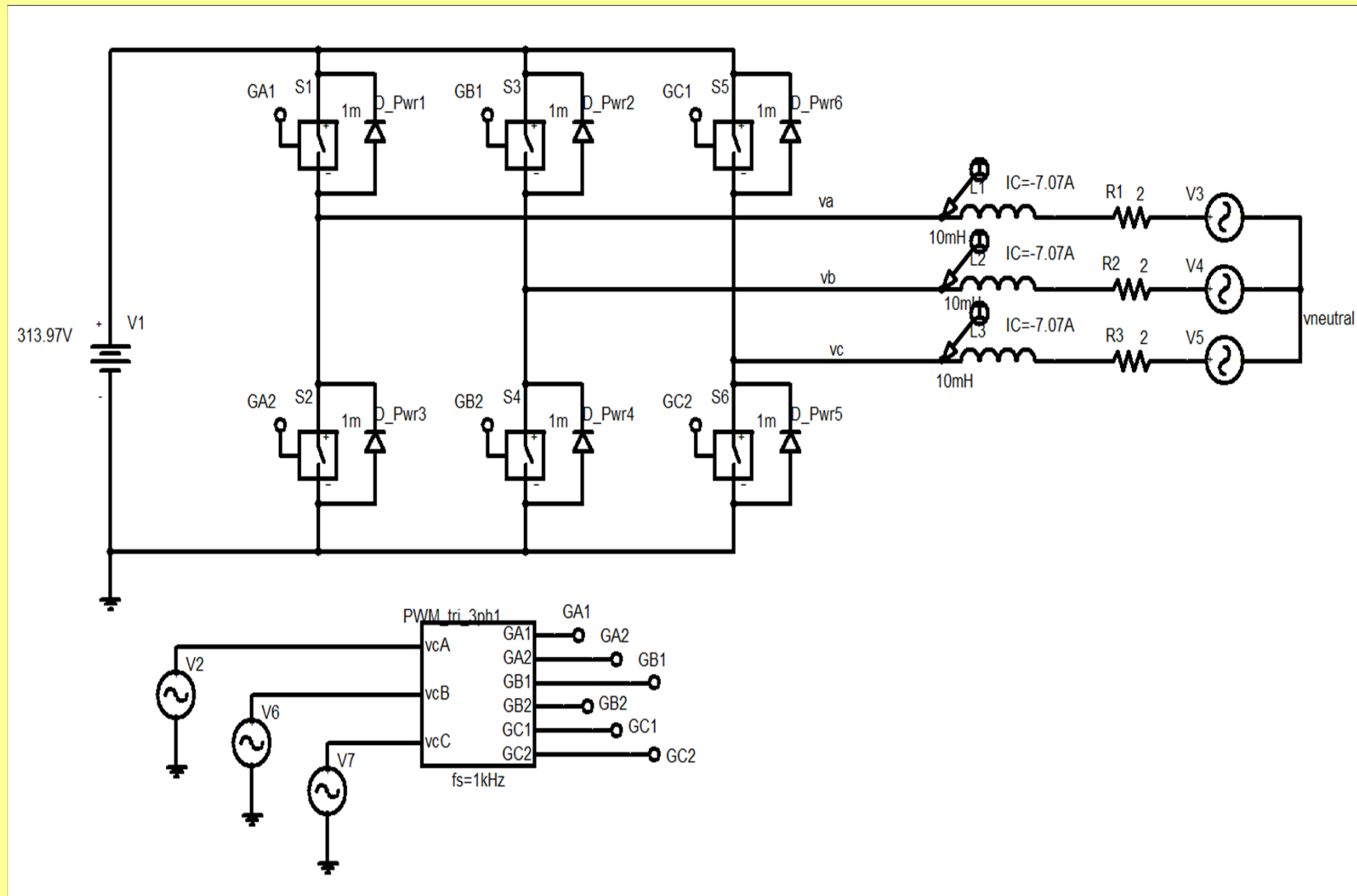

PSpice Modeling:

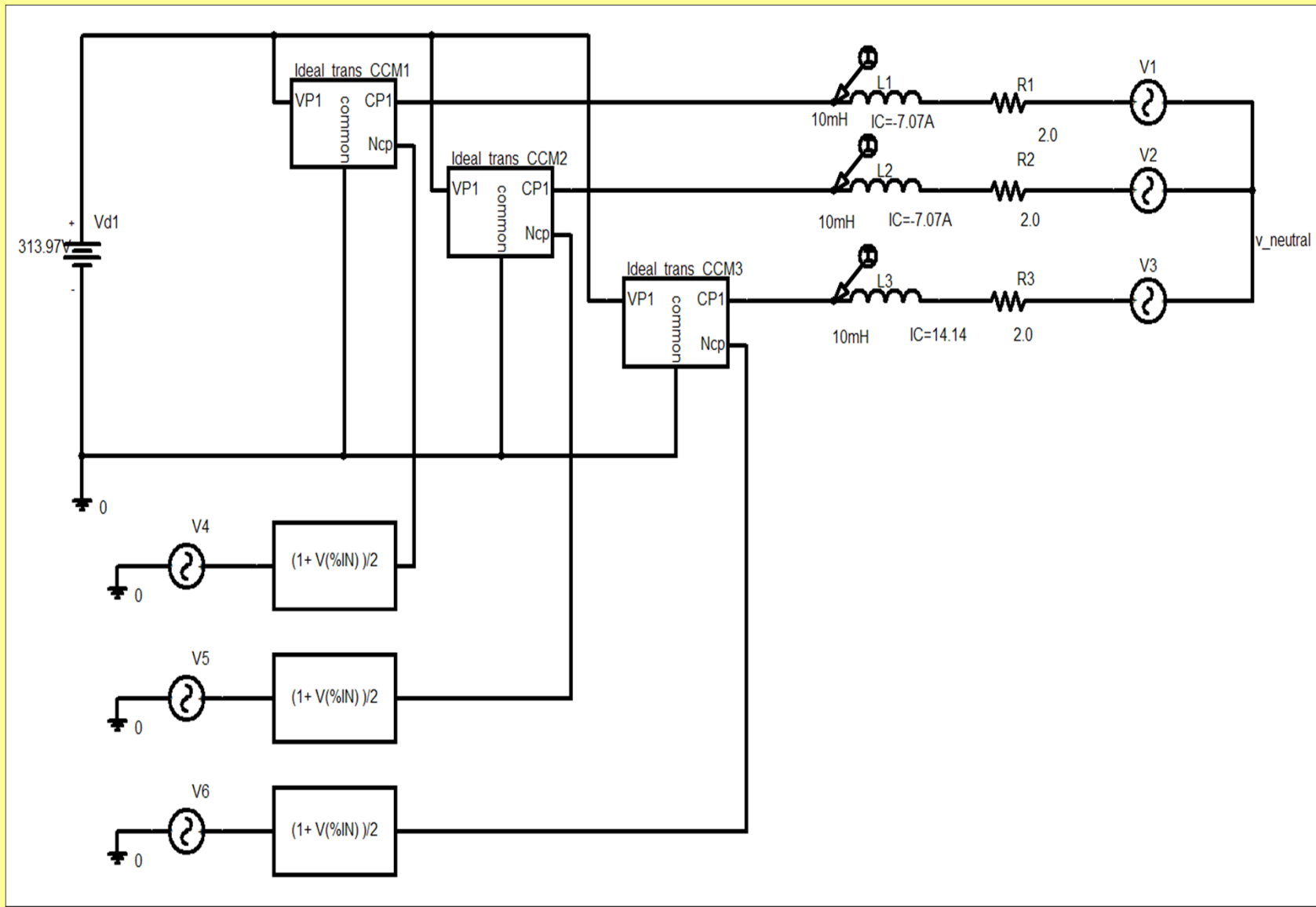

Simulation Results

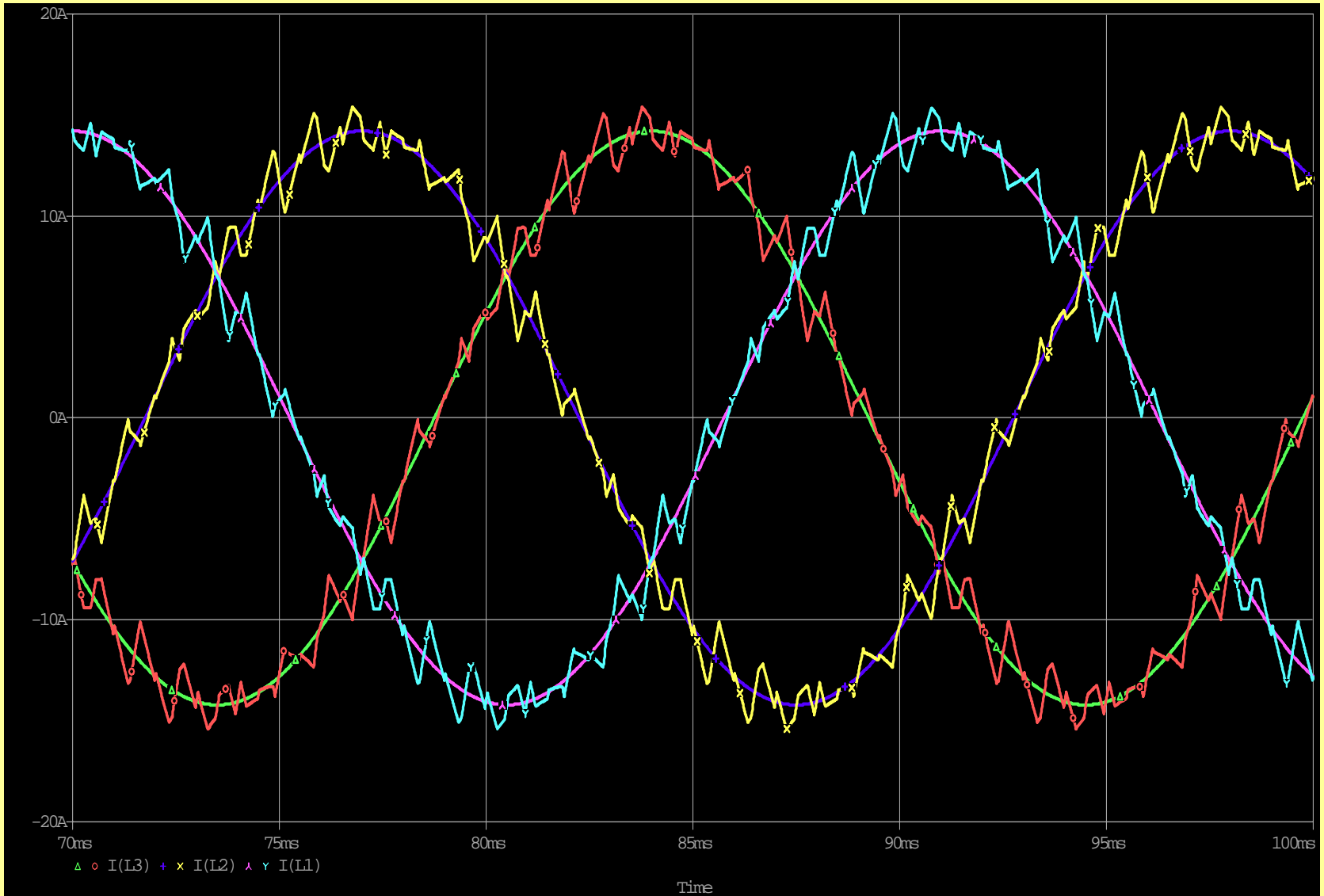

Summary

Synthesis of dc and low-frequency ac waveforms

- Applications in DC-DC Motor Drives
- Applications in Single-Phase AC
- Application in Three-Phase AC Motor Drives