



Alexander-Sadiku

Fundamentals of Electric Circuits

Chapter 4

Circuit Theorems

Copyright © The McGraw-Hill Companies, Inc. Permission required for reproduction or display.

1



Circuit Theorems - Chapter 4

- 4.1 Motivation
- 4.2 Linearity Property
- 4.3 Superposition
- 4.4 Source Transformation
- 4.5 Thevenin's Theorem
- 4.6 Norton's Theorem
- 4.7 Maximum Power Transfer

2

4.1 Motivation (1)

If you are given the following circuit, are there any other alternative(s) to determine the voltage across 2Ω resistor?

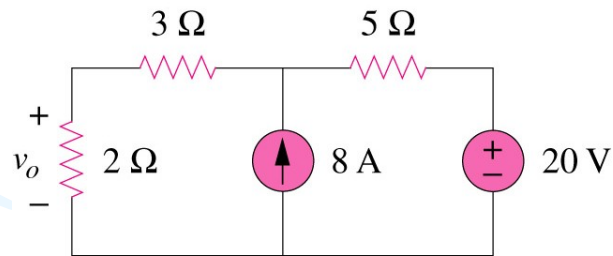

What are they? And how?

Can you work it out by inspection?

3

4.2 Linearity Property (1)

It is the property of an element describing a linear relationship between cause and effect.

A linear circuit is one whose output is linearly related (or directly proportional) to its input.

Homogeneity (scaling) property

$$v = i R \quad \rightarrow \quad k v = k i R$$

Additive property

$$v_1 = i_1 R \text{ and } v_2 = i_2 R \\ \rightarrow v = (i_1 + i_2) R = v_1 + v_2$$

4

4.2 Linearity Property (2)

Example 1

By assume $I_o = 1$ A, use linearity to find the actual value of I_o in the circuit shown below.

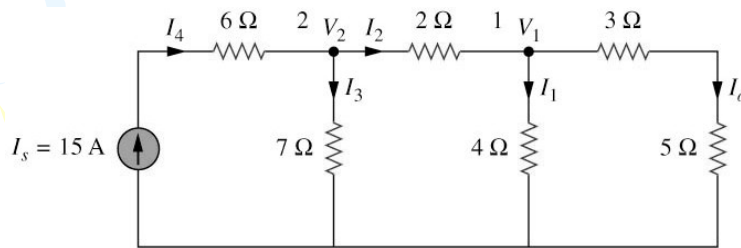

*Refer to in-class illustration, text book, answer $I_o = 3$ A

5

4.3 Superposition Theorem (1)

It states that the voltage across (or current through) an element in a linear circuit is the algebraic sum of the voltage across (or currents through) that element due to EACH independent source acting alone.

The principle of superposition helps us to analyze a linear circuit with more than one independent source by calculating the contribution of each independent source separately.

6

4.3 Superposition Theorem (2)

We consider the effects of 8A and 20V one by one, then add the two effects together for final v_o .

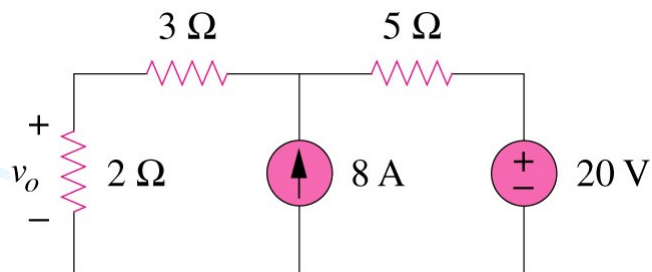

7

4.3 Superposition Theorem (3)

Steps to apply superposition principle

1. Turn off all independent sources except one source. Find the output (voltage or current) due to that active source using nodal or mesh analysis.
2. Repeat step 1 for each of the other independent sources.
3. Find the total contribution by adding algebraically all the contributions due to the independent sources.

8

4.3 Superposition Theorem (4)

Two things have to be kept in mind:

1. When we say turn off all other independent sources:
 - Independent voltage sources are replaced by 0 V (**short circuit**) and
 - Independent current sources are replaced by 0 A (**open circuit**).
2. Dependent sources **are left** intact because they are controlled by circuit variables.

9

4.3 Superposition Theorem (5)

Example 2

Use the superposition theorem to find v in the circuit shown below.

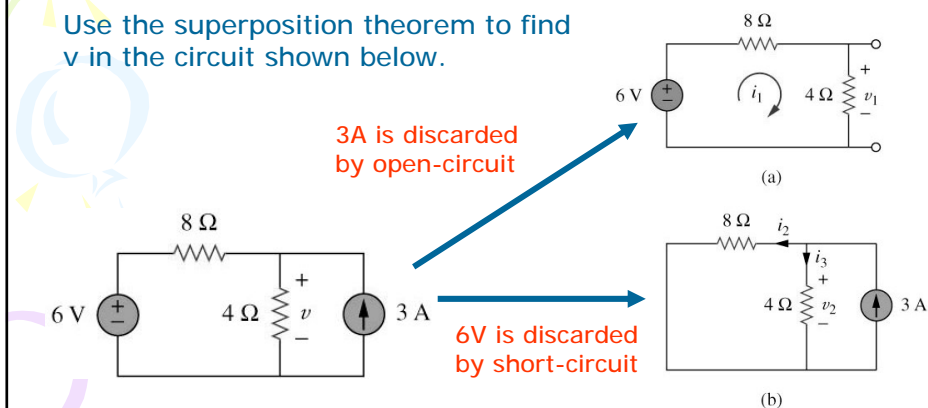

*Refer to in-class illustration, text book, answer $v = 10\text{ V}$

10

4.3 Superposition Theorem (6)

Example 3

Use superposition to find v_x in the circuit below.

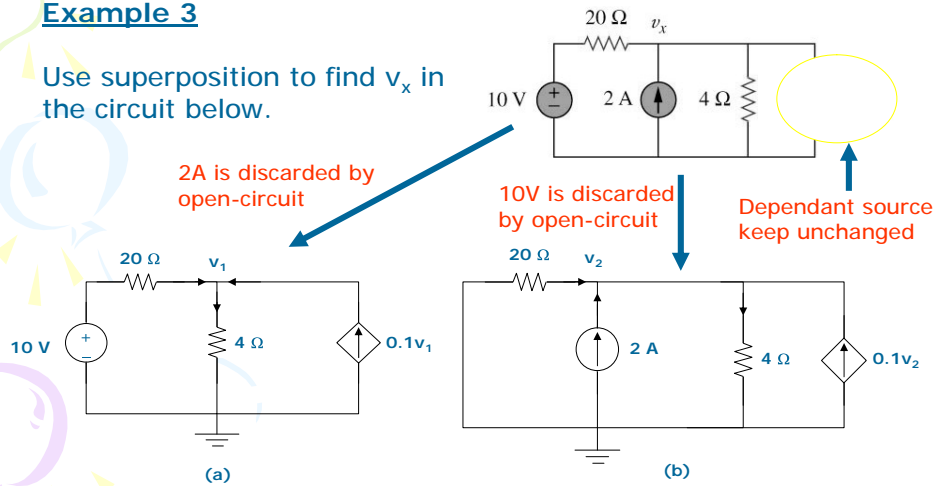

*Refer to in-class illustration, text book, answer $V_x = 12.5V$

11

4.4 Source Transformation (1)

An equivalent circuit is one whose $v-i$ characteristics are identical with the original circuit.

It is the process of replacing a voltage source v_s in series with a resistor R by a current source i_s in parallel with a resistor R , or vice versa.

12

4.4 Source Transformation (2)

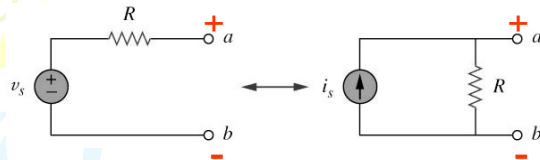

(a) Independent source transform

The arrow of the current source is directed toward the positive terminal of the voltage source.

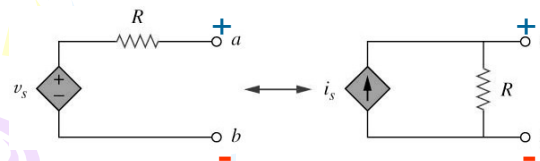

(b) Dependent source transform

The source transformation is not possible when $R = 0$ for voltage source and $R = \infty$ for current source.

13

4.4 Source Transformation (3)

Example 4

Find i_o in the circuit shown below using source transformation.

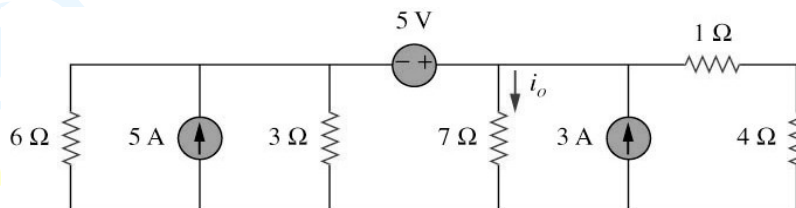

*Refer to in-class illustration, textbook, answer $i_o = 1.78A$

14

4.5 Thevenin's Theorem (1)

It states that a linear two-terminal circuit (Fig. a) can be replaced by an equivalent circuit (Fig. b) consisting of a voltage source V_{TH} in series with a resistor R_{TH} ,

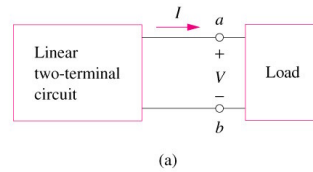

where

V_{TH} is the open-circuit voltage at the terminals.

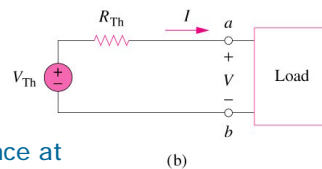

R_{TH} is the input or equivalent resistance at the terminals when the independent sources are turned off.

15

4.5 Thevenin's Theorem (2)

Example 5

Using Thevenin's theorem, find the equivalent circuit to the left of the terminals in the circuit shown below. Hence find i .

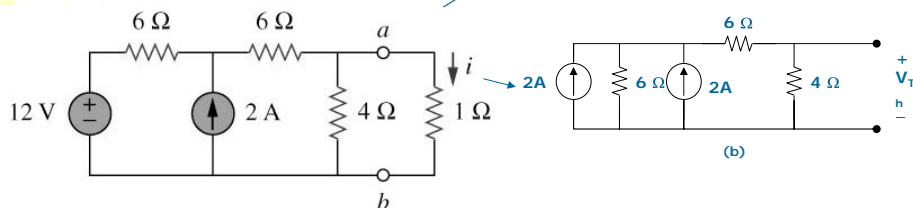

16

*Refer to in-class illustration, textbook, answer $V_{TH} = 6V$, $R_{TH} = 3\Omega$, $i = 1.5A$

4.5 Thevenin's Theorem (3)

Example 6

Find the Thevenin equivalent circuit of the circuit shown below to the left of the terminals.

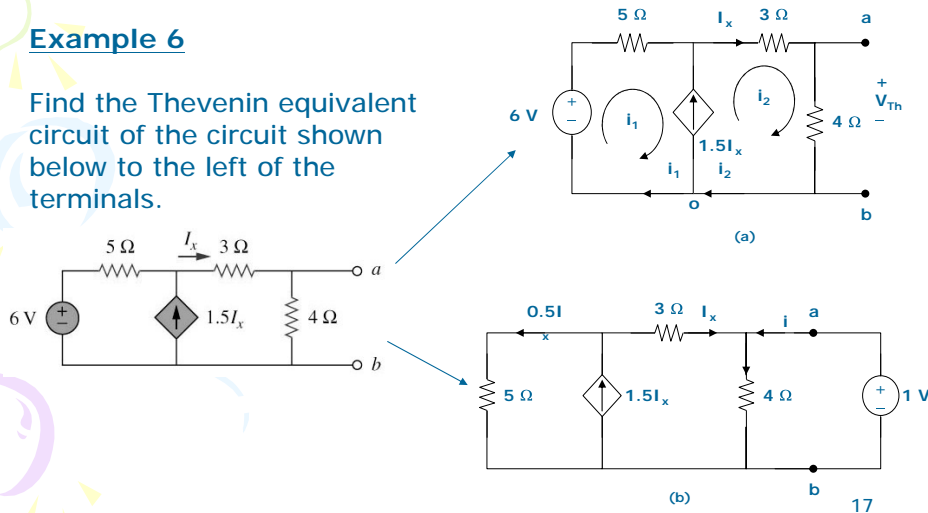

*Refer to in-class illustration, textbook, answer $V_{TH} = 5.33V$, $R_{TH} = 3\Omega$

4.6 Norton's Theorem (1)

It states that a linear two-terminal circuit can be replaced by an equivalent circuit of a current source I_N in parallel with a resistor R_N .

Where

I_N is the short circuit current through the terminals.

R_N is the input or equivalent resistance at the terminals when the independent sources are turned off.

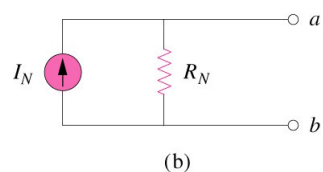
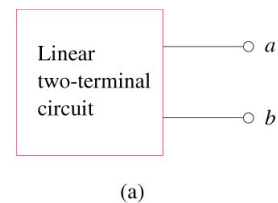

The Thevenin's and Norton equivalent circuits are related by a source transformation.

18

4.6 Norton's Theorem (2)

Example 7

Find the Norton equivalent circuit of the circuit shown below.

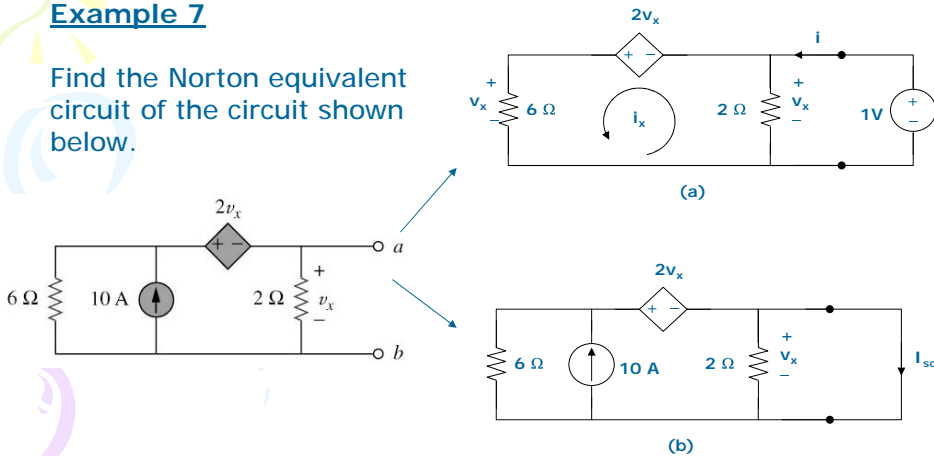

*Refer to in-class illustration, textbook, $R_N = 1\Omega$, $I_N = 10A$.

19

4.7 Maximum Power Transfer (1)

If the entire circuit is replaced by its **Thevenin equivalent** except for the load, the power delivered to the load is:

$$P = i^2 R_L = \left(\frac{V_{Th}}{R_{Th} + R_L} \right)^2 R_L$$

For maximum power dissipated in R_L , P_{max} , for a given R_{Th} , and V_{Th} ,

$$R_L = R_{Th} \Rightarrow P_{max} = \frac{V_{Th}^2}{4R_L}$$

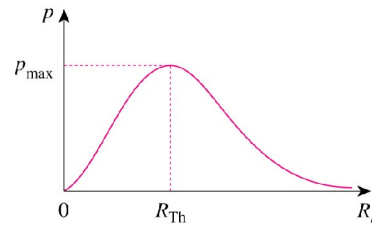
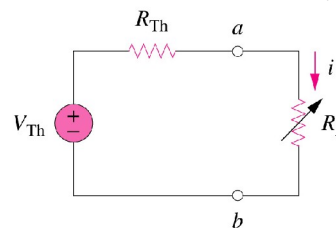

The power transfer profile with different R_L

20

4.7 Maximum Power Transfer (2)

Example 8

Determine the value of R_L that will draw the maximum power from the rest of the circuit shown below. Calculate the maximum power.

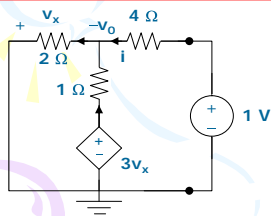
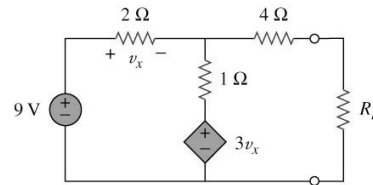

(a)

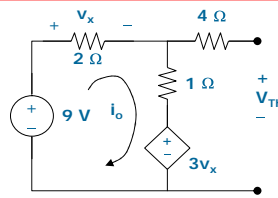

(b)

Fig. a

=> To determine R_{TH}

Fig. b

=> To determine V_{TH}

*Refer to in-class illustration, textbook, $R_L = 4.22\Omega$, $P_m = 2.901W$ 21

This document was created with Win2PDF available at <http://www.daneprairie.com>.
The unregistered version of Win2PDF is for evaluation or non-commercial use only.