

L -Channel QMF Banks

- The basic structure of the L -channel QMF bank is shown below

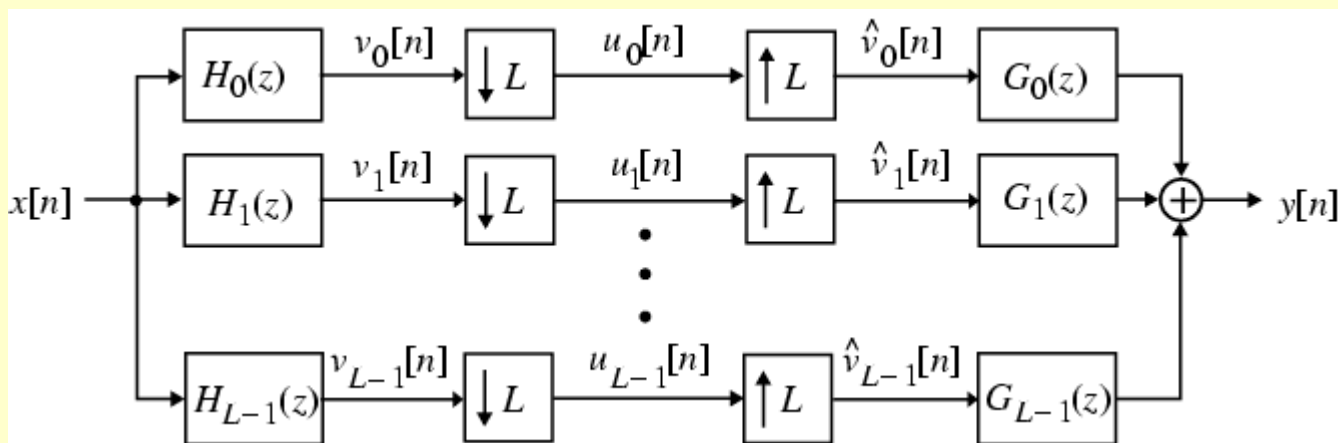

- The expressions for the z -transforms of various intermediate signals in the above structure are given by

L-Channel QMF Banks

$$V_k(z) = H_k(z)X(z)$$

$$U_k(z) = \frac{1}{L} \sum_{\ell=0}^{L-1} H_k(z^{1/L}W_L^\ell)X(z^{1/L}W_L^\ell)$$

$$\hat{V}_k(z) = U_k(z^L)$$

where $0 \leq k \leq L-1$

- Define the vector of down-sampled subband signals as

$$\mathbf{u}(z) = [U_0(z) \quad U_1(z) \quad \cdots \quad U_{L-1}(z)]^T$$

L-Channel QMF Banks

- Define the modulation vector of the input signals as

$$\mathbf{x}^{(m)}(z) = [X(z) \quad X(zW_L) \quad \cdots \quad X(zW_L^{L-1})]^T$$

- Define the analysis filter bank modulation matrix as

$$\mathbf{H}^{(m)}(z) = \begin{bmatrix} H_0(z) & H_1(z) & \cdots & H_{L-1}(z) \\ H_0(zW_L) & H_1(zW_L) & \cdots & H_{L-1}(zW_L) \\ \vdots & \vdots & \ddots & \vdots \\ H_0(zW_L^{L-1}) & H_1(zW_L^{L-1}) & \cdots & H_{L-1}(zW_L^{L-1}) \end{bmatrix}$$

L-Channel QMF Banks

- Then we can write the set of L equations

$$U_k(z) = \frac{1}{L} \sum_{\ell=0}^{L-1} H_k(z^{1/L} W_L^\ell) X(z^{1/L} W_L^\ell)$$

as

$$\mathbf{u}(z) = \frac{1}{L} [\mathbf{H}^{(m)}(z^{1/L})]^T \mathbf{x}^{(m)}(z^{1/L})$$

- The output of the QMF bank is given by

$$Y(z) = \sum_{k=0}^{L-1} G_k(z) \hat{V}_k(z)$$

L-Channel QMF Banks

- In matrix form we can write

$$Y(z) = \mathbf{g}^T(z)\mathbf{u}(z^L)$$

where

$$\mathbf{g}(z) = [G_0(z) \quad G_1(z) \quad \cdots \quad G_{L-1}(z)]^T$$

Alias-Free L -Channel QMF Banks

- From the output equation

$$Y(z) = \mathbf{g}^T(z)\mathbf{u}(z^L)$$

the modulated versions of the output signal are given by

$$Y(zW_L^k) = \mathbf{g}^T(zW_L^k)\mathbf{u}(z^LW_L^{kL}) = \mathbf{g}^T(zW_L^k)\mathbf{u}(z^L),$$

$$0 \leq k \leq L-1$$

Alias-Free L -Channel QMF Banks

- Define the modulation vector of the output signal as

$$\mathbf{y}^{(m)}(z) = [Y(z) \ Y(zW_L) \ \cdots \ Y(zW_L^{L-1})]^T$$

- Define the synthesis filter bank modulation matrix as

$$\mathbf{G}^{(m)}(z) = \begin{bmatrix} G_0(z) & G_1(z) & \cdots & G_{L-1}(z) \\ G_0(zW_L) & G_1(zW_L) & \cdots & G_{L-1}(zW_L) \\ \vdots & \vdots & \ddots & \vdots \\ G_0(zW_L^{L-1}) & G_1(zW_L^{L-1}) & \cdots & G_{L-1}(zW_L^{L-1}) \end{bmatrix}$$

Alias-Free L -Channel QMF Banks

- Then the modulation vector of the output signal can be expressed as

$$\mathbf{y}^{(m)}(z) = \mathbf{G}^{(m)}(z)\mathbf{u}(z^{1/L})$$

- Combining the above and

$$\mathbf{u}(z) = \frac{1}{L} [\mathbf{H}^{(m)}(z^{1/L})]^T \mathbf{x}^{(m)}(z^{1/L})$$

we arrive at

$$\mathbf{y}^{(m)}(z) = \frac{1}{L} \mathbf{G}^{(m)}(z) [\mathbf{H}^{(m)}(z)]^T \mathbf{x}^{(m)}(z)$$

Alias-Free L -Channel QMF Banks

- Using the notation

$$\mathbf{T}(z) = \frac{1}{L} \mathbf{G}^{(m)}(z) [\mathbf{H}^{(m)}(z)]^T$$

we can write

$$\mathbf{y}^{(m)}(z) = \mathbf{T}(z) \mathbf{x}^{(m)}(z)$$

- $\mathbf{T}(z)$ is called the transfer matrix relating the input signal $X(z)$ and its modulated versions $X(zW_L^k)$ with the output signal $Y(z)$ and its modulated versions $Y(zW_L^k)$

Alias-Free L -Channel QMF Banks

- The filter bank is alias-free if the transfer matrix $\mathbf{T}(z)$ is a diagonal matrix of the form

$$\mathbf{T}(z) = \text{diag}[T(z) \quad T(zW_L) \quad \cdots \quad T(zW_L^{L-1})]$$

- The first element $T(z)$ of the above diagonal matrix is called the distortion transfer function of the L -channel filter bank

Alias-Free L -Channel QMF Banks

- Substituting

$$V_k(z) = H_k(z)X(z)$$

$$U_k(z) = \frac{1}{L} \sum_{\ell=0}^{L-1} H_k(z^{1/L}W_L^\ell)X(z^{1/L}W_L^\ell)$$

$$\hat{V}_k(z) = U_k(z^L)$$

in

$$Y(z) = \sum_{k=0}^{L-1} G_k(z)\hat{V}_k(z)$$

Alias-Free L -Channel QMF Banks

we arrive at

$$Y(z) = \sum_{\ell=0}^{L-1} a_{\ell}(z) X(zW_L^{\ell})$$

where

$$a_{\ell}(z) = \frac{1}{L} \sum_{k=0}^{L-1} H_k(zW_L^{\ell}) G_k(z), \quad 0 \leq \ell \leq L-1$$

- On the unit circle the term $X(zW_L^{\ell})$ becomes

$$X(e^{j\omega}W_L^{\ell}) = X(e^{j(\omega-2\pi\ell/L)})$$

Alias-Free L -Channel QMF Banks

- Thus, from

$$Y(z) = \sum_{\ell=0}^{L-1} a_{\ell}(z) X(zW_L^{\ell})$$

we observe that the output spectrum $Y(e^{j\omega})$ is a weighted sum of $X(e^{j\omega})$ and its uniformly shifted versions $X(e^{j(\omega-2\pi\ell/L)})$ for $\ell = 1, 2, \dots, L-1$ which are caused by the sampling rate alteration operations

Alias-Free L -Channel QMF Banks

- The term $X(zW_L^\ell)$ is called the ℓ -th aliasing term, with $a_\ell(z)$ representing its gain at the output
- In general, the L -channel QMF bank is a linear, time-varying system with a period L
- It follows from $Y(z) = \sum_{\ell=0}^{L-1} a_\ell(z) X(zW_L^\ell)$ that the aliasing effect at the output can be completely eliminated if and only if

$$a_\ell(z) = 0, \quad 1 \leq \ell \leq L-1$$

Alias-Free L -Channel QMF Banks

- Note: The aliasing cancellation condition given above must hold for all possible inputs
- If the aliasing cancellation condition holds then the L -channel QMF bank becomes a linear, time-invariant system with an input-output relation given by

$$Y(z) = T(z)X(z)$$

Alias-Free L -Channel QMF Banks

- The distortion transfer function $T(z)$ is given by

$$T(z) = a_0(z) = \frac{1}{L} \sum_{k=0}^{L-1} H_k(z)G_k(z)$$

- If $T(z)$ has a constant magnitude, then the L -channel QMF bank is magnitude-preserving
- If $T(z)$ has a linear phase, then the L -channel QMF bank is phase-preserving
- If $T(z)$ is a pure delay, then it is a perfect reconstruction filter bank

Alias-Free L -Channel QMF Banks

- Define

$$\mathbf{A}(z) = [a_0(z) \quad a_1(z) \quad \cdots \quad a_{L-1}(z)]$$

- Then

$$a_\ell(z) = \frac{1}{L} \sum_{k=0}^{L-1} H_k(zW_L^\ell) G_k(z), \quad 0 \leq \ell \leq L-1$$

can be expressed as

$$L \cdot \mathbf{A}(z) = \mathbf{H}^{(m)}(z) \mathbf{g}(z)$$

Alias-Free L -Channel QMF Banks

- The aliasing cancellation condition can now be rewritten as

$$\mathbf{H}^{(m)}(z)\mathbf{g}(z) = \mathbf{t}(z)$$

where

$$\mathbf{t}(z) = [La_0(z) \quad 0 \quad \dots \quad 0]^T$$

Alias-Free L -Channel QMF Banks

- Hence, knowing the set of analysis filters $\{H_k(z)\}$, we can determine the desired set of synthesis filters $\{G_k(z)\}$ as

$$\mathbf{g}(z) = [\mathbf{H}^{(m)}(z)]^{-1} \mathbf{t}(z)$$

provided $[\det \mathbf{H}^{(m)}(z)] \neq 0$

- Moreover, a perfect reconstruction QMF bank results if we set $T(z) = z^{-n_o}$ in the expression for $\mathbf{t}(z)$

Alias-Free L -Channel QMF Banks

- In practice, the above approach is difficult to carry out for a number of reasons
- A more practical solution to the design of a perfect reconstruction QMF bank is based on a polyphase representation

Polyphase Representation

- Consider the L -band Type I polyphase representation of the k -th analysis filter:

$$H_k(z) = \sum_{\ell=0}^{L-1} z^{-\ell} E_{k\ell}(z^L), \quad 0 \leq k \leq L-1$$

- A matrix representation of the above set of equations is given by

$$\mathbf{h}(z) = \mathbf{E}(z^L)\mathbf{e}(z)$$

where

$$\mathbf{h}(z) = [H_0(z) \quad H_1(z) \quad \cdots \quad H_{L-1}(z)]^T$$

Polyphase Representation

$$\mathbf{e}(z) = [1 \quad z^{-1} \quad \cdots \quad z^{-(L-1)}]^T$$

and

$$\mathbf{E}(z) = \begin{bmatrix} E_{00}(z) & E_{01}(z) & \cdots & E_{0,L-1}(z) \\ E_{10}(z) & E_{11}(z) & \cdots & E_{1,L-1}(z) \\ \vdots & \vdots & \ddots & \vdots \\ E_{L-1,0}(z) & E_{L-1,1}(z) & \cdots & E_{L-1,L-1}(z) \end{bmatrix}$$

- $\mathbf{E}(z)$ is called the Type I polyphase component matrix

Polyphase Representation

- Likewise, we can represent the L synthesis filters in a L -band Type II polyphase form:

$$G_k(z) = \sum_{\ell=0}^{L-1} z^{-(L-1-\ell)} R_{\ell k}(z^L), \quad 0 \leq k \leq L-1$$

- In matrix form the above set of equations can be rewritten as

$$\mathbf{g}^T(z) = z^{-(L-1)} \tilde{\mathbf{e}}(z) \mathbf{R}(z^L)$$

where

$$\mathbf{g}(z) = [G_0(z) \quad G_1(z) \quad \cdots \quad G_{L-1}(z)]^T$$

Polyphase Representation

$$\mathbf{e}(z) = [1 \quad z \quad \cdots \quad z^{L-1}] = \mathbf{e}^T(z^{-1})$$

and

$$\mathbf{R}(z) = \begin{bmatrix} R_{00}(z) & R_{01}(z) & \cdots & R_{0,L-1}(z) \\ R_{10}(z) & R_{11}(z) & \cdots & R_{1,L-1}(z) \\ \vdots & \vdots & \ddots & \vdots \\ R_{L-1,0}(z) & R_{L-1,1}(z) & \cdots & R_{L-1,L-1}(z) \end{bmatrix}$$

- $\mathbf{R}(z)$ is called the Type II polyphase component matrix

Polyphase Representation

- The polyphase representations of the L -channel analysis and the L -channel synthesis filter banks are shown below

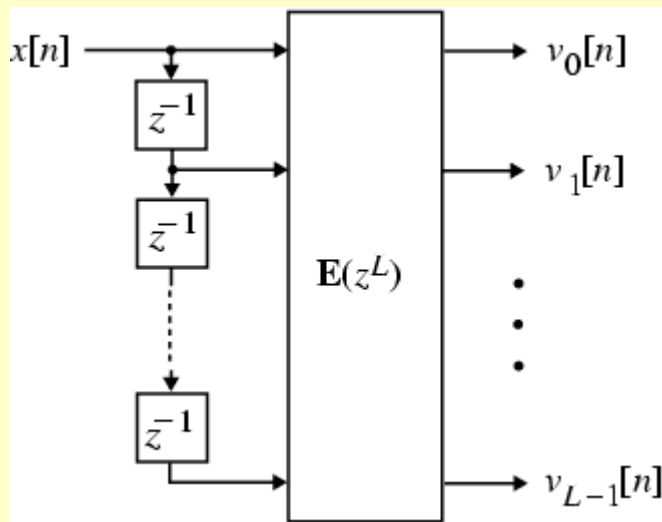

Analysis filter bank

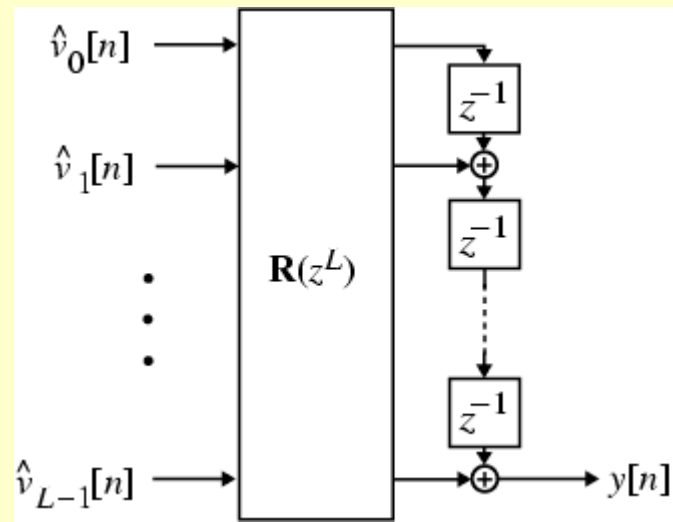

Synthesis filter bank

Polyphase Representation

- Substituting the polyphase representations of the analysis and synthesis filter banks in the original structure of the L -channel QMF bank, and making use of the cascade equivalences we arrive at

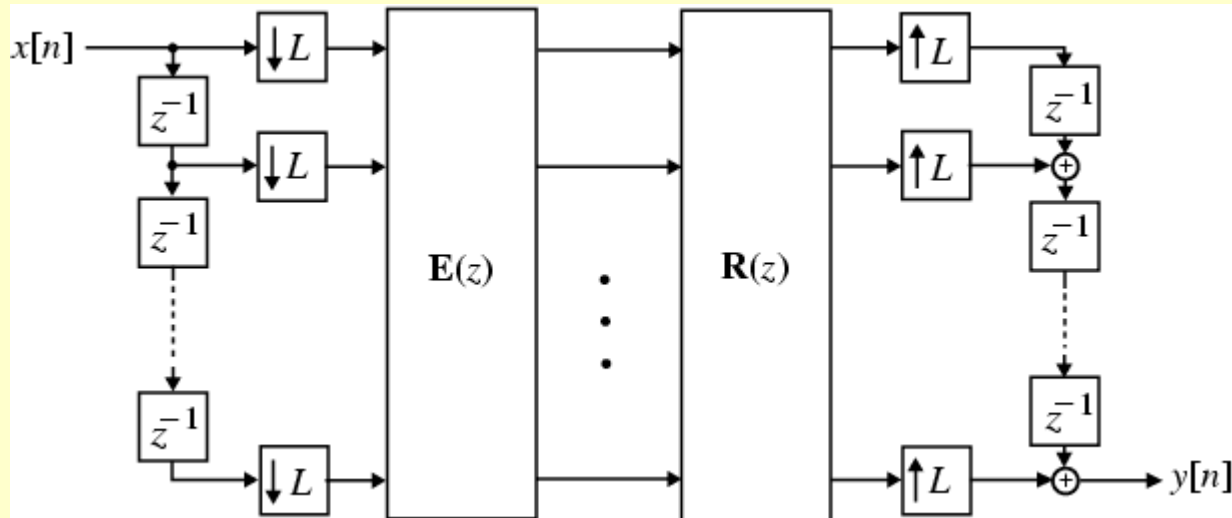

Polyphase Representation

- From

$$\mathbf{H}^{(m)}(z) = \begin{bmatrix} H_0(z) & H_1(z) & \cdots & H_{L-1}(z) \\ H_0(zW_L) & H_1(zW_L) & \cdots & H_{L-1}(zW_L) \\ \vdots & \vdots & \ddots & \vdots \\ H_0(zW_L^{L-1}) & H_1(zW_L^{L-1}) & \cdots & H_{L-1}(zW_L^{L-1}) \end{bmatrix}$$

and $\mathbf{h}(z) = [H_0(z) \ H_1(z) \ \cdots \ H_{L-1}(z)]^T$

it can be seen that

$$[\mathbf{H}^{(m)}(z)]^T = [\mathbf{h}(z) \ \mathbf{h}(zW_L) \ \cdots \ \mathbf{h}(zW_L^{L-1})]$$

Polyphase Representation

- Making use of $\mathbf{h}(z) = \mathbf{E}(z^L)\mathbf{e}(z)$ in the previous equation we get

$$[\mathbf{H}^{(m)}(z)]^T = \mathbf{E}(z^L)[\mathbf{e}(z) \quad \mathbf{e}(zW_L) \quad \dots \quad \mathbf{e}(zW_L^{L-1})]$$

- Now, from $\mathbf{e}(z) = [1 \quad z^{-1} \quad \dots \quad z^{-(L-1)}]^T$ we have

$$\mathbf{e}(zW_L^k) = \Delta(z) \begin{bmatrix} 1 \\ W_L^{-k} \\ \vdots \\ W_L^{-k(L-1)} \end{bmatrix}$$

Polyphase Representation

where we have used the notation

$$\Delta(z) = \text{diag}[1 \quad z^{-1} \quad \dots \quad z^{-(L-1)}]$$

- Making use of the above notation in

$$[\mathbf{H}^{(m)}(z)]^T = \mathbf{E}(z^L)[\mathbf{e}(z) \quad \mathbf{e}(zW_L) \quad \dots \quad \mathbf{e}(zW_L^{L-1})]$$

we arrive at

$$\mathbf{H}(z) = \mathbf{D}^\dagger \Delta(z) \mathbf{E}^T(z^L)$$

where \mathbf{D}^\dagger is the conjugate transpose of the $L \times L$ DFT matrix \mathbf{D}

Condition for Perfect Reconstruction

- Consider the L -channel QMF structure repeated below for convenience

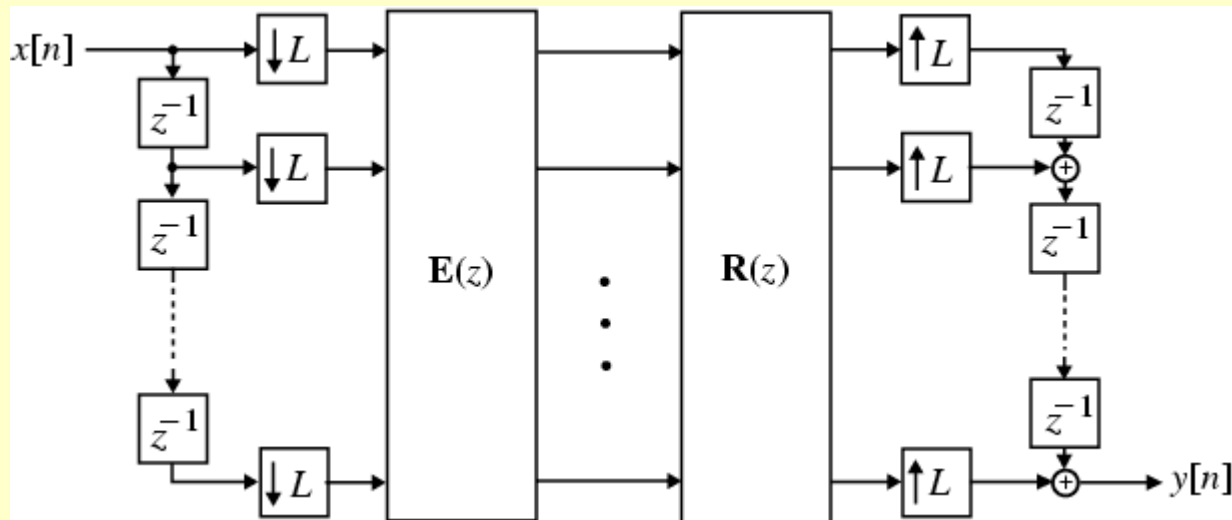

Condition for Perfect Reconstruction

- Assume that the polyphase component matrices satisfy the relation

$$\mathbf{R}(z)\mathbf{E}(z) = c\mathbf{I}$$

where \mathbf{I} is an $L \times L$ identity matrix and c is a constant

- Then the QMF structure on the previous slide reduces to the one shown on the next slide

Condition for Perfect Reconstruction

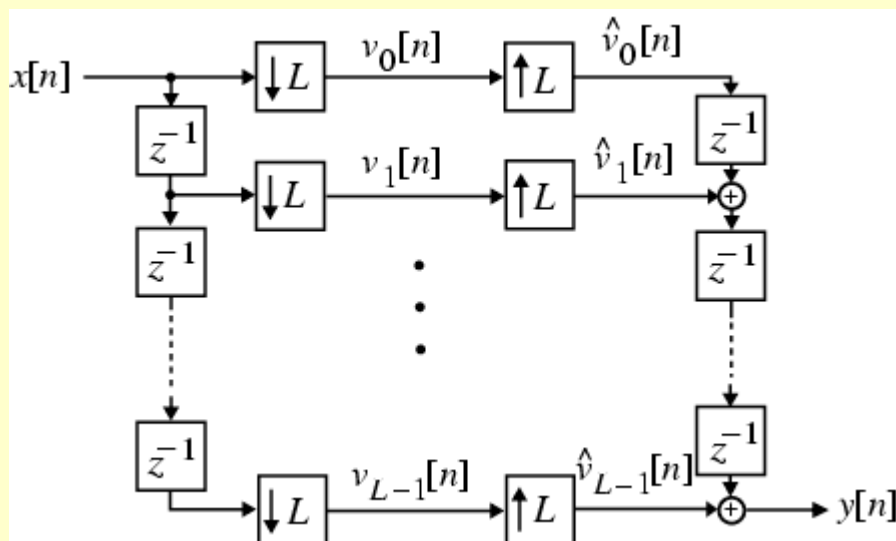

- Note: The structure can be considered as a special case of the most general L -channel QMF bank shown earlier if we set

$$H_k(z) = z^{-k}, \quad G_k(z) = z^{-(L-1-k)}, \quad 0 \leq k \leq L-1$$

Condition for Perfect Reconstruction

- Substituting

$$H_k(z) = z^{-k}, \quad G_k(z) = z^{-(L-1-k)}, \quad 0 \leq k \leq L-1$$

in

$$a_\ell(z) = \frac{1}{L} \sum_{k=0}^{L-1} H_k(zW_L^\ell) G_k(z), \quad 0 \leq \ell \leq L-1$$

we get

$$a_\ell(z) = z^{-(L-1)} \left(\frac{1}{L} \sum_{k=0}^{L-1} W_L^{-\ell k} \right), \quad 0 \leq \ell \leq L-1$$

Condition for Perfect Reconstruction

- Now, $\frac{1}{L} \sum_{\ell=0}^{L-1} W_L^{-\ell k} = \begin{cases} 1, & \ell = 0 \\ 0, & 1 \leq \ell \leq L-1 \end{cases}$
- Hence, from the last equation on the previous slide it follows that
$$a_0(z) = 1, \quad a_\ell(z) = 0 \quad \text{for } \ell \neq 0$$
- As a result, $T(z) = z^{-(L-1)}$ or in other words, the simplified QMF structure satisfies the perfect reconstruction property

Condition for Perfect Reconstruction

- The analysis and synthesis filters of the perfect reconstruction L -channel QMF bank can be easily determined from known polyphase component matrices
- Example - The structure shown below is by construction a perfect reconstruction filter bank

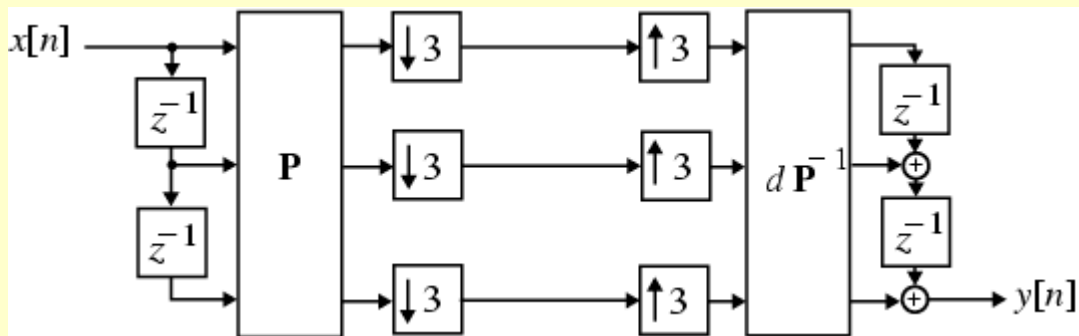

Condition for Perfect Reconstruction

- The output of the filter bank is simply

$$y[n] = dx[n - 2]$$

- Note: In this structure $\mathbf{E}(z^3) = \mathbf{P}$ and $\mathbf{R}(z^3) = d\mathbf{P}^{-1}$

- Consider

$$\mathbf{P} = \begin{bmatrix} 1 & 1 & 1 \\ 1 & -1 & 1 \\ 1 & 0 & -1 \end{bmatrix}$$

Condition for Perfect Reconstruction

- From $\mathbf{h}(z) = \mathbf{E}(z^3)\mathbf{e}(z)$ we get

$$\begin{aligned} \begin{bmatrix} H_0(z) \\ H_1(z) \\ H_2(z) \end{bmatrix} &= \begin{bmatrix} E_{00}(z) & E_{01}(z) & E_{02}(z) \\ E_{10}(z) & E_{11}(z) & E_{12}(z) \\ E_{20}(z) & E_{21}(z) & E_{22}(z) \end{bmatrix} \begin{bmatrix} 1 \\ z^{-1} \\ z^{-2} \end{bmatrix} \\ &= \begin{bmatrix} 1 & 1 & 1 \\ 1 & -1 & 1 \\ 1 & 0 & -1 \end{bmatrix} \begin{bmatrix} 1 \\ z^{-1} \\ z^{-2} \end{bmatrix} \end{aligned}$$

- Hence,

$$\begin{aligned} H_0(z) &= 1 + z^{-1} + z^{-2}, & H_1(z) &= 1 - z^{-1} + z^{-2}, \\ H_2(z) &= 1 - z^{-2} \end{aligned}$$

Condition for Perfect Reconstruction

- With $d = 4$ we have $d\mathbf{P}^{-1} = \begin{bmatrix} 1 & 1 & 2 \\ 2 & -2 & 0 \\ 1 & 1 & -2 \end{bmatrix}$
- Then from $\mathbf{g}^T(z) = z^{-(L-1)}\tilde{\mathbf{e}}(z)\mathbf{R}(z^3)$ we get

$$\begin{bmatrix} G_0(z) \\ G_1(z) \\ G_2(z) \end{bmatrix} = \begin{bmatrix} z^{-2} & z^{-1} & 1 \end{bmatrix} \begin{bmatrix} 1 & 1 & 2 \\ 2 & -2 & 0 \\ 1 & 1 & -2 \end{bmatrix}$$

which leads to

$$G_0(z) = 1 + 2z^{-1} + z^{-2}, \quad G_1(z) = 1 - 2z^{-1} + z^{-2},$$

$$G_2(z) = -2 + 2z^{-2}$$

Polyphase Representation

- For a given L -channel analysis filter bank, the polyphase component matrix $\mathbf{E}(z)$ is known

$$\mathbf{E}(z)\mathbf{E}(z) = c\mathbf{I},$$

- Hence, a perfect reconstruction L -channel QMF bank can be designed by constructing a synthesis filter bank with a polyphase component matrix

$$\mathbf{R}(z) = [\mathbf{E}(z)]^{-1}$$

Polyphase Representation

- In general, it is not easy to compute the inverse of a rational $L \times L$ matrix
- An alternative elegant approach is to design the analysis filter bank with an invertible polyphase matrix $\mathbf{E}(z)$
- For example, $\mathbf{E}(z)$ can be chosen to be a paraunitary matrix satisfying the condition

$$\tilde{\mathbf{E}}(z)\mathbf{E}(z) = c\mathbf{I}, \quad \text{for all } z$$

Polyphase Representation

- Note: $\tilde{\mathbf{E}}(z)$ is the paraconjugate of $\mathbf{E}(z)$ given by the transpose of $\mathbf{E}(z^{-1})$, with each coefficient replaced by its conjugate
- A perfect reconstruction L -channel QMF bank is then obtained by choosing

$$\mathbf{R}(z) = \tilde{\mathbf{E}}(z)$$

Polyphase Representation

- For the design of a perfect reconstruction L -channel QMF bank, the matrix $\mathbf{E}(z)$ can be expressed in a product form

$$\mathbf{E}(z) = \mathbf{E}_R(z)\mathbf{E}_{R-1}(z)\cdots\mathbf{E}_1(z)\mathbf{E}_0$$

where \mathbf{E}_0 is a constant unitary matrix, and

$$\mathbf{E}_\ell(z) = \mathbf{I} - \mathbf{v}_\ell[\mathbf{v}_\ell^*]^T + z^{-1}\mathbf{v}_\ell[\mathbf{v}_\ell^*]^T$$

- In the above \mathbf{v}_ℓ is a column vector of order L with unit norm, i.e., $[\mathbf{v}_\ell^*]^T \mathbf{v}_\ell = 1$

Polyphase Representation

- With $\mathbf{E}(z)$ expressed in the product form, one can set up an appropriate objective function that can be minimized to arrive at a set of analysis filters meeting the desired specifications
- To this end, a suitable objective function is given by

$$\phi = \sum_{k=0}^{L-1} \int_{k\text{-th stopband}} |H(e^{j\omega})|^2 d\omega$$

Polyphase Representation

- The optimization parameters are the elements of \mathbf{v}_ℓ and \mathbf{E}_0
- Example - Consider the design of a 3-channel FIR perfect reconstruction QMF bank with a passband width $\pi/3$
- The passband width of the lowpass filter is from 0 to $\pi/3$, that of the bandpass filter is from $\pi/3$ to $2\pi/3$, and that of the highpass filter is from $2\pi/3$ to π

Polyphase Representation

- The objective function to be minimized here is thus of the form

$$\begin{aligned}\phi = & \int_{\frac{\pi}{3}+\varepsilon}^{\pi} |H_0(e^{j\omega})|^2 d\omega + \int_0^{\frac{\pi}{3}-\varepsilon} |H_1(e^{j\omega})|^2 d\omega \\ & + \int_{\frac{2\pi}{3}+\varepsilon}^{\pi} |H_1(e^{j\omega})|^2 d\omega + \int_0^{\frac{2\pi}{3}-\varepsilon} |H_2(e^{j\omega})|^2 d\omega\end{aligned}$$

- The gain responses of the 3 analysis filters of length 15 are shown on the next slide

Polyphase Representation

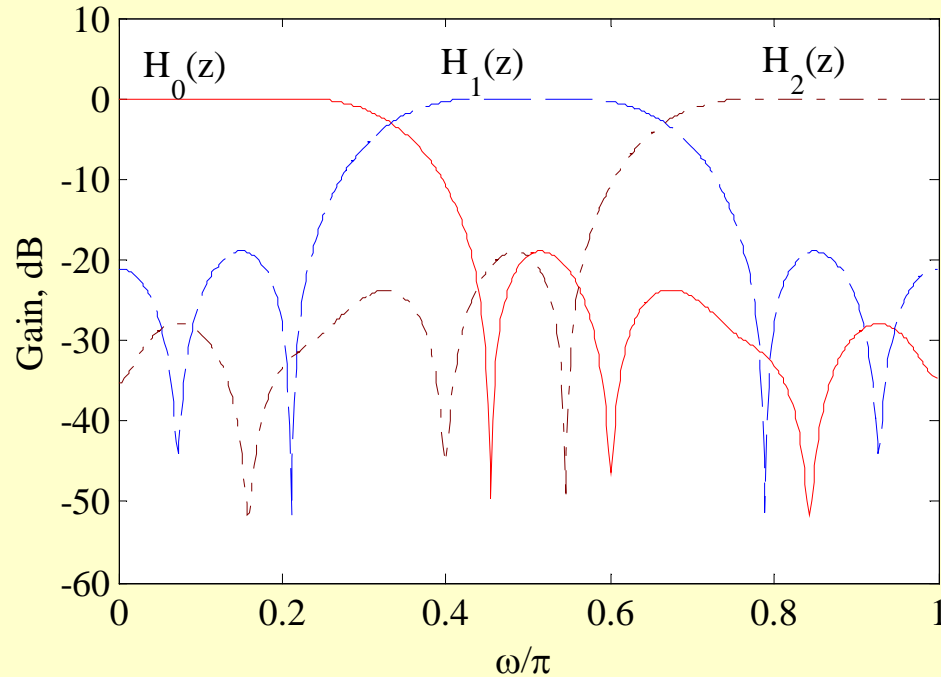

- The coefficients of the corresponding synthesis filters are given by

$$g_k[n] = h_k[14 - n], \quad k = 1, 2, 3$$